



# 2024

**NOVEDADES**  
NEW PRODUCTS  
NOUVEAUTÉS



[izartool.com](http://izartool.com)

Ref. **8402**

**MICRO BROCA METAL DURO GRAN RENDIMIENTO CNC 5XD**

5XD CNC High Performance Carbide Micro Drill Bit

Micro foret carbure haut rendement CNC 5XD

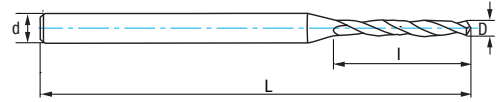

<b>MD/HM</b> Carbure Grano UF	<b>TIALCN</b>	IZAR Std.					HRC 45-55	Tol. h8	 <b>Pulido Espejo</b> Mirror Polished Polyglass	<b>5XD</b>
-------------------------------------	---------------	--------------	--	--	--	--	--------------	------------	--	------------

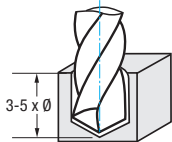

$$r.p.m. = \frac{Vc \times 1.000}{\pi \times \phi}$$

$$Vf (mm/min.) = r.p.m. \times f$$

Material		Vc (m/min)	Avances f/rev. (mm/rev) - Feed - Pas
Grupo	Sub.	TIALCN	Diam. 1,0-2,9
P	P.1	28-48	0,080-0,160
	P.2	24-45	0,070-0,160
	P.3	20-40	0,065-0,145
	P.5	24-40	0,070-0,145
M		16-32	0,048-0,120
K	K.1	32-48	0,080-0,160
	K.2	28-44	0,080-0,160

D mm	d mm	L mm	l mm		N° Art. TIALCN	€
1,00	3,00	50	8	1	69992	
1,10	3,00	50	8	1	70004	
1,20	3,00	50	8	1	70007	
1,30	3,00	50	8	1	70031	
1,40	3,00	50	9	1	70034	
1,50	3,00	50	9	1	70037	
1,60	3,00	50	10	1	70040	
1,70	3,00	50	10	1	70043	
1,80	3,00	50	12	1	70046	
1,90	3,00	50	12	1	70055	

D mm	d mm	L mm	l mm		N° Art. TIALCN	€
2,00	3,00	50	12	1	70058	
2,10	3,00	50	12	1	70061	
2,20	3,00	50	13	1	70064	
2,30	3,00	50	13	1	70067	
2,40	3,00	50	14	1	70070	
2,50	3,00	50	14	1	70073	
2,60	3,00	50	14	1	70076	
2,70	3,00	50	16	1	70079	
2,80	3,00	50	16	1	70082	
2,90	3,00	50	16	1	70085	



Ref. **9075**

**BROCA MD 3Z ALTO AVANCE**

High Feed **3Z** Carbide Drill Bit

Foret carbure **3Z** haute avance

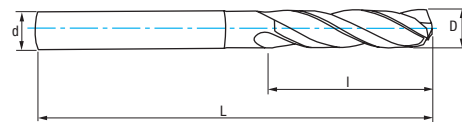

<b>MD/HM</b> Carbure Grano UF	<b>X-AICr</b>	IZAR Std.				<b>3 Z</b>	 Pulido Espejo Mirror Polished Polyglass	<b>3XD</b>
-------------------------------------	---------------	--------------	--	--	--	------------	---	------------

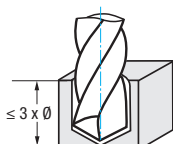

Material		Vc (m/min)	Avances f/rev. (mm/rev) - Feed - Pas				
Grupo	Sub.	X-AICr	Ø 4	Ø 6	Ø 8	Ø 10	Ø 12
P	P.1	100-120	0,135	0,210	0,300	0,360	0,420
	P.2	90-110	0,135	0,210	0,300	0,360	0,420
	P.5	50-65	0,060	0,098	0,128	0,180	0,210
M		60-70	0,060	0,098	0,128	0,180	0,210
K	K.1	125-150	0,203	0,218	0,300	0,353	0,398
	K.2	90-110	0,180	0,203	0,263	0,278	0,300
N	N.3	90-300	0,120	0,190	0,266	0,320	0,370
	N.4	90-300	0,120	0,190	0,266	0,320	0,370
	N.5	70-150	0,120	0,190	0,266	0,320	0,370



$$r.p.m. = \frac{Vc \times 1.000}{\pi \times \phi}$$

$$Vf (mm/min.) = r.p.m. \times f$$

D mm	d mm	L mm	l mm		Nº Art. X-AICr	€
3,00	4,00	46	16	1	20210	
3,30	4,00	49	18	1	20211	
3,50	4,00	52	20	1	20213	
4,00	4,00	55	22	1	20215	
4,20	6,00	55	22	1	20216	
4,50	6,00	58	24	1	20221	
5,00	6,00	62	26	1	20226	
5,50	6,00	66	28	1	20228	
6,00	6,00	66	28	1	20236	
6,50	8,00	70	31	1	20242	
6,80	8,00	74	34	1	20247	
7,00	8,00	74	34	1	20253	

D mm	d mm	L mm	l mm		Nº Art. X-AICr	€
7,50	8,00	74	34	1	20262	
8,00	8,00	79	36	1	20270	
8,50	10,00	79	36	1	20273	
9,00	10,00	84	40	1	20275	
9,50	10,00	84	40	1	20280	
10,00	10,00	89	43	1	20282	
10,20	12,00	89	43	1	20284	
10,50	12,00	89	43	1	20288	
11,00	12,00	95	47	1	20290	
11,50	12,00	95	47	1	20291	
12,00	12,00	102	51	1	20294	
13,00	14,00	102	51	1	20295	

- Avance hasta **x2** comparando con broca 2Z convencional.
- Recubrimiento Alto Rendimiento X-AICr.
- Agujeros más precisos con mejor acabado superficial.
- Punta Autocentrante.
- .. to **x2** feed vs standard 2Z drill bits.
- High performance X-AICr coating with polished surface.
- Remarkably accurate holes and outstanding surface finishing.
- Self-centering function geometry.
- Avance jusqu'à **x2** par rapport au foret 2Z conventionnel.
- Revêtement haute performance X-AICr avec surface polie.
- Trous plus précis avec une meilleure finition de surface.
- Pointe d'auto-centrage.



▶ Video



Ref. **1032**

**BROCA MANGO CILINDRICO METALMAX. SERIE CORTA**

METALMAX Cobalt Drill Bit. Jobber Series

Foret cobalt METALMAX. Série courte

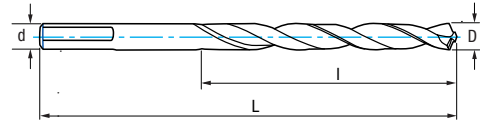

HSSE 5%Co	DIN 338 W		40°	$\geq \phi 4$	$< 4$ mm		<b>Ambar</b> Gold Finish Finition Or	<b>Rectificado</b> Ground Taillé meulé	Tol. D h8
--------------	--------------	--	-----	---------------	-------------	--	--	--	--------------

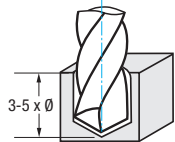

$$r.p.m. = \frac{Vc \times 1000}{\pi \times \phi}$$

$$Vf (mm/min.) = r.p.m. \times f$$

Material		Vc (m/min)	Avances f/rev. (mm/rev) - Feed - Pas							
Grupo	Sub.	5% Co	Ø 2	Ø 3	Ø 4	Ø 5	Ø 6	Ø 8	Ø 10	Ø 12
P	P.1	30-35	0,045	0,055	0,070	0,080	0,100	0,120	0,150	0,160
	P.5	8-12	0,030	0,040	0,050	0,060	0,070	0,090	0,100	0,120
M		6-12	0,030	0,040	0,050	0,060	0,070	0,090	0,100	0,120
N	N.1	30-40	0,050	0,070	0,080	0,100	0,120	0,140	0,170	0,200
	N.2		0,060	0,090	0,100	0,120	0,150	0,180	0,210	0,250
	N.3	60-80	0,080	0,110	0,130	0,150	0,190	0,220	0,260	0,320
	N.4		0,080	0,110	0,130	0,150	0,190	0,220	0,260	0,320
	N.5		0,060	0,090	0,100	0,120	0,150	0,180	0,210	0,250

D mm	L mm	I mm		N° Art. 5% Co	€
1,00	34	12	10	44820	
1,50	40	18	10	44822	
2,00	49	24	10	15169	
2,50	57	30	10	44823	
3,00	61	33	10	15191	
3,30	65	36	10	84181	
3,50	70	39	10	15193	
4,00	75	43	10	15215	
4,20	75	43	10	15238	
4,50	80	47	10	15243	
5,00	86	52	10	15244	
5,50	93	57	10	15247	
6,00	93	57	10	15265	
6,50	101	63	10	15270	
6,80	109	69	10	84182	

D mm	L mm	I mm		N° Art. 5% Co	€
7,00	109	69	10	15273	
7,50	109	69	10	15280	
8,00	117	75	10	15282	
8,50	117	75	5	15283	
9,00	125	81	5	15285	
9,50	125	81	5	44825	
10,00	133	87	5	15291	
10,20	133	87	5	84183	
10,50	133	87	5	15292	
11,00	142	94	5	15298	
11,50	142	94	5	44828	
12,00	151	101	5	15303	
12,50	151	101	5	44831	
13,00	151	101	5	15304	



Ref. **1052**

**BROCA MANGO CILÍNDRICO HSS ZIRKONIO. SERIE EXTRA CORTA**

HSS Zirkonio Straight Shank Drill Bit. Stub Series

Foret queue cylindrique HSS Zirkonio. Série extra-courte

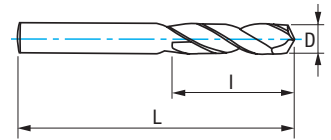

HSS	Zirkonio	DIN 1897 N	135°	DIN 1412 C ≥ 2 mm				Rectificado Ground Taillé meulé	Tol. D h8
-----	----------	------------	------	-------------------	--	--	--	------------------------------------	-----------

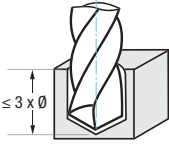

Material		Vc (m/min)	Avances f/rev. (mm/rev) - Feed - Pas									
Grupo	Sub.	Zirkonio	Ø 2	Ø 3	Ø 4	Ø 5	Ø 6	Ø 8	Ø 10	Ø 12	Ø 16	
P	P.1	33-40	0,045	0,055	0,070	0,080	0,100	0,120	0,150	0,160	0,180	
K	K.1	40-45	0,060	0,090	0,100	0,120	0,150	0,180	0,210	0,250	0,300	
	K.2	33-40	0,050	0,070	0,080	0,100	0,120	0,140	0,170	0,200	0,240	
N	N.3	80-105	0,080	0,110	0,130	0,150	0,190	0,220	0,260	0,320	0,380	
	N.4		0,080	0,110	0,130	0,150	0,190	0,220	0,260	0,320	0,380	
	N.5	50-65	0,060	0,090	0,100	0,120	0,150	0,180	0,210	0,250	0,300	

r.p.m. =  $\frac{Vc \times 1.000}{\pi \times \phi}$  Vf (mm/min.) = r.p.m. x f

D mm	L mm	I mm		Nº Art. Zirkonio	€
1,00	26	6	10	44999	
1,10	28	7	10	48470	
1,20	30	8	10	48476	
1,25	30	8	10	45458	
1,30	30	8	10	48479	
1,40	32	9	10	48482	
1,50	32	9	10	45002	
1,60	34	10	10	45005	
1,70	34	10	10	48488	
1,75	36	11	10	45464	
1,80	36	11	10	45026	
1,90	36	11	10	45028	
2,00	38	12	10	24853	
2,10	40	13	10	45065	
2,20	40	13	10	45068	
2,25	40	13	10	48785	
2,30	40	13	10	45071	
2,40	43	14	10	45074	
2,50	43	14	10	24898	
2,60	43	14	10	24899	
2,70	46	16	10	45078	
2,75	46	16	10	45470	
2,80	46	16	10	45080	
2,90	46	16	10	45083	
3,00	46	16	10	24900	
3,10	49	18	10	45128	
3,20	49	18	10	24901	
3,25	49	18	10	24902	
3,30	49	18	10	24903	
3,40	52	20	10	45134	
3,50	52	20	10	24905	
3,60	52	20	10	45153	
3,70	52	20	10	45154	
3,75	52	20	10	45473	
3,80	55	22	10	45163	
3,90	55	22	10	45165	
4,00	55	22	10	24906	
4,10	55	22	10	24913	
4,20	55	22	10	24943	
4,25	55	22	10	45491	
4,30	58	24	10	25027	
4,40	58	24	10	45197	
4,50	58	24	10	25028	
4,60	58	24	10	45200	
4,70	58	24	10	45203	
4,75	58	24	10	45500	
4,80	62	26	10	45206	
4,90	62	26	10	25061	

D mm	L mm	I mm		Nº Art. Zirkonio	€
5,00	62	26	10	25064	
5,10	62	26	10	45212	
5,20	62	26	10	25066	
5,25	62	26	10	45512	
5,30	62	26	10	45218	
5,40	66	28	10	45221	
5,50	66	28	10	25072	
5,60	66	28	10	45224	
5,70	66	28	10	45227	
5,75	66	28	10	45515	
5,80	66	28	10	45230	
5,90	66	28	10	45341	
6,00	66	28	10	25075	
6,10	70	31	10	45353	
6,20	70	31	10	45356	
6,25	70	31	10	45524	
6,30	70	31	10	45359	
6,40	70	31	10	45362	
6,50	70	31	10	25078	
6,60	70	31	10	45365	
6,70	70	31	10	45368	
6,75	74	34	10	45527	
6,80	74	34	10	25081	
6,90	74	34	10	48494	
7,00	74	34	10	25085	
7,10	74	34	10	48497	
7,20	74	34	10	45374	
7,25	74	34	10	45530	
7,30	74	34	10	48503	
7,40	74	34	10	45377	
7,50	74	34	10	25091	
7,60	79	37	10	48506	
7,70	79	37	10	48533	
7,75	79	37	10	45536	
7,80	79	37	10	45380	
7,90	79	37	10	48539	
8,00	79	37	10	25102	
8,10	79	37	10	48542	
8,20	79	37	10	48548	
8,25	79	37	10	45539	
8,30	79	37	10	48551	
8,40	79	37	10	48554	
8,50	79	37	10	25106	
8,70	84	40	10	45383	
8,75	84	40	10	45542	
8,80	84	40	10	48557	
8,90	84	40	10	48560	
9,00	84	40	10	25130	

D mm	L mm	I mm		Nº Art. Zirkonio	€
9,10	84	40	10	45386	
9,20	84	40	10	48563	
9,25	84	40	10	45545	
9,30	84	40	10	48566	
9,40	84	40	10	48569	
9,50	84	40	10	25132	
9,60	89	43	10	48572	
9,70	89	43	10	48575	
9,75	89	43	10	45548	
9,80	89	43	10	48578	
9,90	89	43	10	48581	
10,00	89	43	10	25135	
10,10	89	43	1	48584	
10,20	89	43	1	25137	
10,25	89	43	1	45551	
10,30	89	43	1	48587	
10,50	89	43	1	25138	
10,80	95	47	1	48590	
11,00	95	47	1	25139	
11,10	95	47	1	48788	
11,20	95	47	1	48593	
11,25	95	47	1	45557	
11,50	95	47	1	45389	
11,80	95	47	1	48602	
12,00	102	51	1	25141	
12,10	102	51	1	48605	
12,20	102	51	1	48608	
12,25	102	51	1	45560	
12,50	102	51	1	25142	
12,70	102	51	1	45563	
13,00	102	51	1	25143	
13,50	107	54	1	45392	
14,00	107	54	1	45398	
14,50	111	56	1	45419	
15,00	111	56	1	45422	
15,25	115	58	1	48800	
15,50	115	58	1	45425	
15,75	115	58	1	48791	
16,00	115	58	1	45428	
16,50	119	60	1	45572	
17,00	119	60	1	45575	
17,50	123	62	1	45577	
18,00	123	62	1	45578	
18,50	127	64	1	45585	
19,00	127	64	1	45588	
19,50	131	66	1	45597	
20,00	131	66	1	45614	





Set **1029**  
**BROCA MULTI ACERO**  
 Multi-Steel Drill Bit  
 Foret multi-acier



Ø mm	Uds	Ø mm	Uds	Ø mm	Uds
1,00	10	5,50	10	10,00	10
1,50	10	6,00	10	10,50	5
2,00	10	6,50	10	11,00	5
2,50	10	7,00	10	11,50	5
3,00	10	7,50	10	12,00	5
3,50	10	8,00	10	12,50	5
4,00	10	8,50	10	13,00	5
4,50	10	9,00	10		
5,00	10	9,50	10		

**220 Pcs**    **Nº Art. BORDEAUX**    €  
 41037

Set **1032**  
**BROCA COBALTO METALMAX**  
 METALMAX Cobalt Drill Bit  
 Foret cobalt METALMAX



Ø mm	Uds	Ø mm	Uds	Ø mm	Uds
1,00	10	5,50	10	10,00	10
1,50	10	6,00	10	10,50	5
2,00	10	6,50	10	11,00	5
2,50	10	7,00	10	11,50	5
3,00	10	7,50	10	12,00	5
3,50	10	8,00	10	12,50	5
4,00	10	8,50	10	13,00	5
4,50	10	9,00	10		
5,00	10	9,50	10		

**220 Pcs**    **Nº Art. HSSE**    €  
 41034

Sets **1404**

**JUEGO BROCAS 99 PCS (1-10x0,1mm + 10-13x0,5mm + Previos roscado 10-13mm)**  
 Drill Bit Set. **99 pcs.** (1-10x0,1mm + 10-13x0,5mm + Before Threading sizes 10-13mm)  
 Jeu de forets. **99 pcs.** (1-10x0,1mm + 10-13x0,5mm + Pré Taraudage 10-13mm)



Ref. 1016

**Nº Art. 5% Co**    €  
 48821



Ref. 1015

**Nº Art. Zirkonio**    €  
 48824

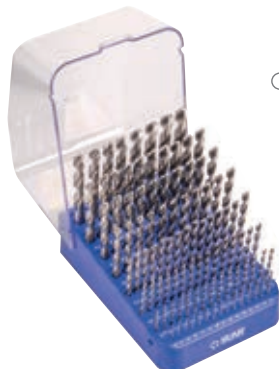

Ref. 1013

**Nº Art. HSS**    €  
 48818

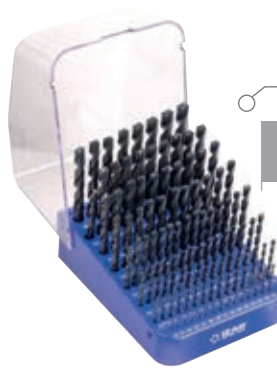

Ref. 1010

**Nº Art. HSS**    €  
 48815



Sets **1410**

**MEDIDOR DE DIÁMETROS**

Diameter gauge  
Jauge de diamètres



**55 Pcs:**

1-13 x 0,5 mm

- Ø1,0 – 4,0 mm: 3 pcs
- Ø4,2 – 8,0 mm: 2 pcs
- Ø8,50 – 13,0 mm: 1 pcs



Ref. 1016



Ref. 1015

Cont. Ø	Nº Art. 5% Co	€
1 - 13 x 0,5 mm	19537	

Cont. Ø	Nº Art. Zirkonio	€
1 - 13 x 0,5 mm	28360	



Ref. 1010



Ref. 1013

Cont. Ø	Nº Art. HSS	€
1 - 13 x 0,5 mm	19535	

Cont. Ø	Nº Art. HSS	€
1 - 13 x 0,5 mm	19536	

Ref. **4073**

**CONO PORTA FRESAS HUECAS**

Holder for annular cutters

Cône pour porte-fraise à carotter pour unité de perçage électromagnétique

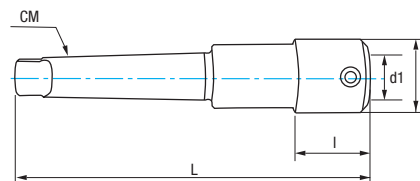

CM	D mm	L mm	I mm	d1 mm	Nº Art. HSS	€
2	37	165	37	19	84115	
3	37	175	37	19	84116	



Llave Allen incluida - Allen key included - Clé Allen incluse



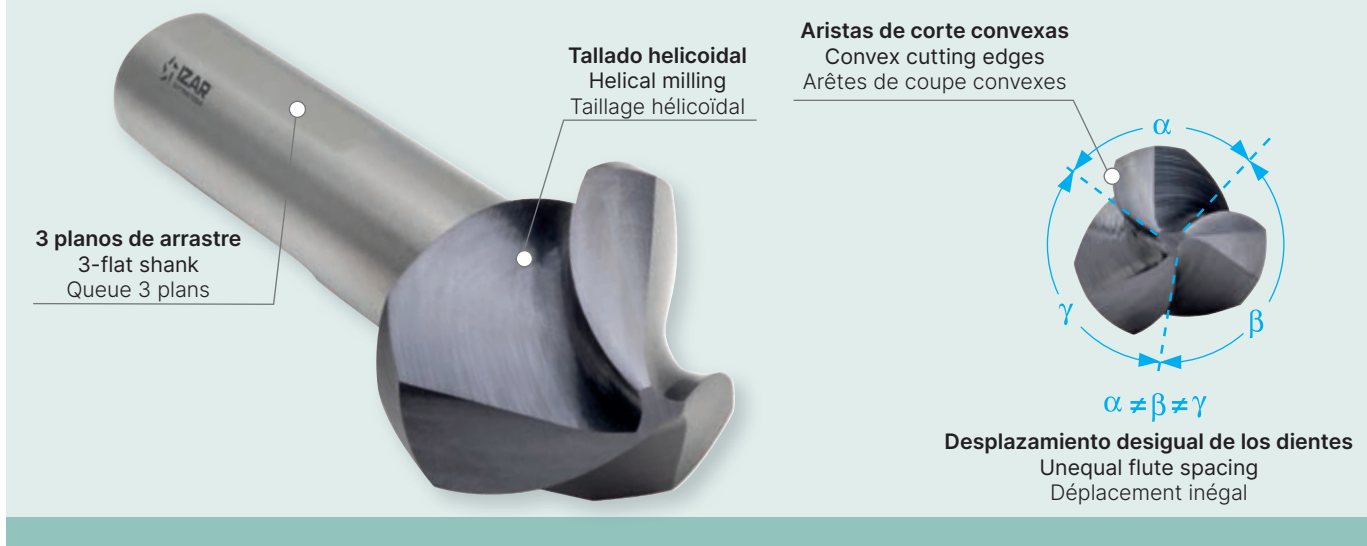

Ref. **2571** **AVELLANADOR ANTIVIBRACIÓN 3Z HELICOIDAL DESPLAZAMIENTO DESIGUAL**  
**Unequal Flute Spacing Spiral Anti-Vibration 3Z Countersink**  
**Fraise à noyer anti-vibration 3Z hélicoïdal déplacement inégal**

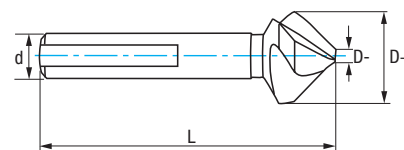

HSSE 5% Co	TIALN	DIN 335 C				3 Z	Tol. D (± 0,05)	Tol. d (h9)	Tol. L (± 1)	Tol. $\alpha$ $\alpha_{-1}^0$
---------------	-------	--------------	--	--	--	-----	--------------------	----------------	-----------------	----------------------------------

**REDUCCIÓN DE LAS FUERZAS DE CORTE**  
 Cutting forces decreased  
 Réduction des forces de coupe

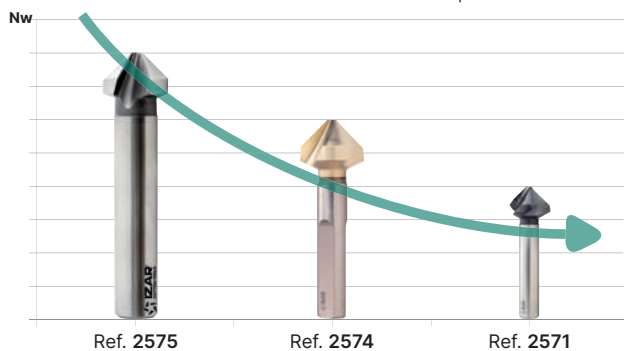

Material		Vc (m/min)	Avances f/rev. (mm/rev) - Feed - Pas					
Grupo	Sub.	TIALN	Ø 6	Ø 8	Ø 10	Ø 12	Ø 16	Ø 25
P	P.1	25-40	0,100	0,100	0,100	0,120	0,160	0,200
	P.2	15-20	0,100	0,100	0,100	0,120	0,160	0,200
	P.3	10-20	0,100	0,100	0,100	0,120	0,160	0,200
	P.4	5-10	0,040	0,040	0,040	0,050	0,050	0,080
	P.5	10-15	0,050	0,050	0,060	0,070	0,070	0,080
M		15-20	0,050	0,050	0,060	0,070	0,070	0,080
K	K.1	20-30	0,100	0,100	0,100	0,120	0,160	0,200
	K.2	20-30	0,100	0,100	0,100	0,120	0,160	0,200
S		10-12	0,050	0,050	0,060	0,070	0,070	0,080
N	N.1	30-40	0,150	0,160	0,170	0,190	0,210	0,260
	N.2	25-30	0,150	0,160	0,170	0,190	0,210	0,260
	N.3	40-100	0,150	0,160	0,170	0,190	0,210	0,260
	N.4	40-100	0,150	0,160	0,170	0,190	0,210	0,260
	N.5	30-40	0,120	0,120	0,140	0,140	0,180	0,220
	N.6	20-50	0,150	0,160	0,170	0,190	0,210	0,260
	N.7	20-40	0,120	0,120	0,140	0,140	0,180	0,220

- Reducción drástica de los esfuerzos de corte
- Avellanado de precisión con el mínimo de rebaba
- Drastic reduction of cutting forces
- Precision countersinking with minimal burr
- Réduction drastique des forces de coupe
- Fraisage de précision avec une bavure minimale

$$r.p.m. = \frac{Vc \times 1.000}{\pi \times \phi} \quad Vf (mm/min.) = r.p.m. \times f$$

D+ mm	D- mm	d mm	L mm	Nº Art TIALN	€
06,30	1,50	5	45	85211	
08,30	2,00	6	50	85212	
10,40	2,50	6	50	85213	
12,40	2,80	8	56	85214	
16,50	3,20	10	60	85215	
20,50	3,50	10	63	85216	
25,00	3,80	10	67	85217	



**Set 6 Pcs**

Cont. Ø	Nº Art TIALN	€
6,3-8,3-10,4-12,4-16,5-20,5	85218	<b>Set Price!</b>





Ref. **2574**

**AVELLANADOR ANTIVIBRACIÓN 3Z DESPLAZAMIENTO DESIGUAL**

Unequal Flute Spacing **Anti-Vibration 3Z** Countersink

Fraise à noyer **anti-vibration 3Z** déplacement inégal

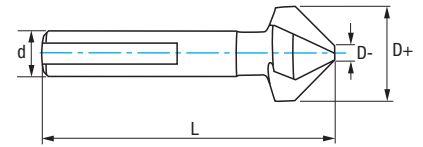

HSSE 5% Co	Zirkonio	DIN 335 C				3 Z	Tol. D (± 0,05)	Tol. d (h9)	Tol. L (± 1)	Tol. $\alpha_1^0$
---------------	----------	--------------	--	--	--	-----	--------------------	----------------	-----------------	-------------------

\* **Mango liso hasta fin de existencias**  
Plain Shank while stock lasts  
Queue plane jusqu'à la fin de stock

Material		Vc (m/min)		Avances f/rev. (mm/rev) - Feed - Pas							
Grupo	Sub.	HSSE	Zirkonio	Ø 6	Ø 8	Ø 10	Ø 16	Ø 20	Ø 25	Ø 32	Ø 40
P	P.1	15-20	17-23	0,060	0,080	0,100	0,120	0,150	0,180	0,200	0,220
	P.5	4-8	5-9	0,030	0,040	0,050	0,060	0,080	0,090	0,100	0,120
M		4-8	5-9	0,040	0,050	0,060	0,080	0,100	0,120	0,140	0,160
N	N.1	20-30	23-35	0,060	0,080	0,100	0,120	0,150	0,180	0,200	0,220
	N.3	15-25	17-29	0,090	0,110	0,130	0,160	0,190	0,210	0,260	0,290
	N.4	15-25	17-29	0,090	0,110	0,130	0,160	0,190	0,210	0,260	0,290
	N.5	8-12	9-14	0,090	0,110	0,130	0,160	0,190	0,210	0,260	0,290
	N.6	20-30	23-35	0,100	0,120	0,150	0,180	0,200	0,220	0,280	0,320

$r.p.m. = \frac{Vc \times 1.000}{\pi \times \phi}$      $Vf (mm/min.) = r.p.m. \times f$

D+ mm	D- mm	d mm	L mm	Nº Art. 5% Co	€	Nº Art. Zirkonio	€
4,30	1,30	4	40	84766		84741	
5,30	1,50	4	40	84767		84746	
6,00	1,50	5	45	84768		84747	
6,30	1,50	5	45	84769		84748	
8,00	2,00	6	50	84770		84749	
8,30	2,00	6	50	84771		84750	
9,40	2,20	6	50	84772		84751	
10,00	2,50	6	50	84773		84752	
10,40	2,50	6	50	84774		84753	
11,50	2,80	8	56	84775		84754	
12,40	2,80	8	56	84776		84757	
15,00	3,20	10	60	84777		84758	
16,50	3,20	10	60	84778		84759	
20,50	3,50	10	63	84779		84760	
25,00	3,80	10	67	84781		84761	
28,00	4,00	12	71	84782		84762	
30,00	4,20	12	71	84783		84763	
31,00	4,20	12	71	84784		84764	
40,00	5,00	15	80	84785		84765	



Set 6 Pcs

Set Price!

Cont. Ø	Nº Art. Zirkonio	€
6,3-8,3-10,4-12,4-16,5-20,5	85219	

- **Avellanador 3Z a 90° "Antivibración"** - Anti-vibration 90° 3Z countersink. - Fraise anti-vibration 90° 3Z.
- **Desplazamiento desigual de los dientes que evita vibraciones y mejora los acabados superficiales de los avellanados.** - Unequal flute spacing geometry avoids vibrations and improves the surface finishing. - Déplacement inégal des dents qui évite les vibrations et améliore les finitions de surface des fraises.
- **Recubrimiento especial de Zirkonio.** - Special Zirkonio coating. - Revêtement spécial Zirkonium.
- **3 planos de arrastre: evita el deslizamiento en el portabrocas.** - 3-flat shank: Prevents slipping in the chuck. - 3 plans : empêche le glissement dans le mandrin

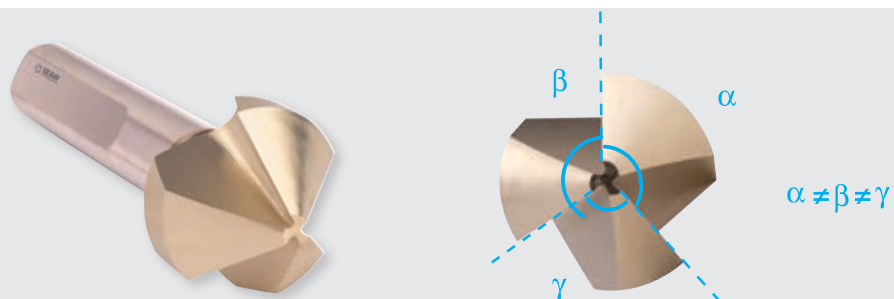

Ref. **3113**

**MACHO HELICOIDAL MÁQUINA MÉTRICA NORMA ISO 529**

ISO 529 Standard Metric Machine Spiral Tap

Taraud hélicoïdal machine métrique norme ISO 529

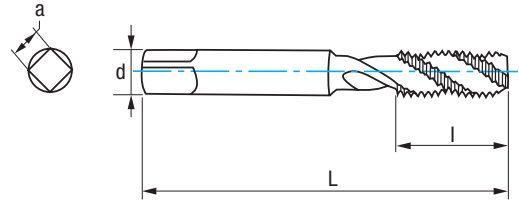

HSSE 5%Co	ISO 529	C 2-3h	Tol. 6H	45°	α 12-14°	60°	Vaporizado Vaporized Vaporisée
--------------	------------	-----------	------------	-----	-------------	-----	--------------------------------------

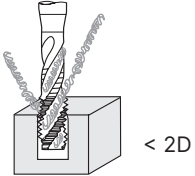

Material		Vc (m/min)
Grupo	Sub.	5% Co
P	P.1	6-10
M		8-12
N	N.1	5-8
	N.3	15-35
	N.4	14-20

Avance  $f = P$  (Paso - Pitch - Pas)

$V_f$  (mm/min.) = r.p.m. x  $f$

$r.p.m. = \frac{V_c \times 1.000}{\pi \times \phi}$

M	P	L mm	l mm	d mm	a mm	Z	N° Art. 5% Co	€
M2	0,40	41	8	2,50	2,00	2	48989	
M2,5	0,45	44	9,5	2,80	2,24	2	48992	
M3	0,50	48	6	3,15	2,50	3	49004	
M3,5	0,60	50	6	3,55	2,80	3	49016	
M4	0,70	53	7	4,00	3,15	3	49019	
M5	0,80	58	8	5,00	4,00	3	49022	
M6	1,00	66	10	6,30	5,00	3	49025	
M7	1,00	66	13	7,10	5,60	3	49028	
M8	1,25	72	12	8,00	6,30	3	49031	
M10	1,50	80	15	10,00	8,00	3	49034	
M12	1,75	89	16	9,00	7,10	3	49187	
M14	2,00	95	18	11,20	9,00	3	49190	
M16	2,00	102	18	12,50	10,00	4	49193	
M18	2,50	112	29	14,00	11,20	4	49196	
M20	2,50	112	29	14,00	11,20	4	49199	
M22	2,50	118	29	16,00	12,50	4	49202	
M24	3,00	130	35	18,00	14,00	4	49205	
M27	3,00	135	35	20,00	16,00	4	77480	
M30	3,50	138	42	20,00	16,00	4	77481	



Ref. **3039**

**MACHO ÚNICO MANO MÉTRICA / MÉTRICA FINA NORMA ISO**

ISO Standard Metric / Metric Fine Hand Single Tap

Taraud à main unique métrique / métrique pas fin norme ISO

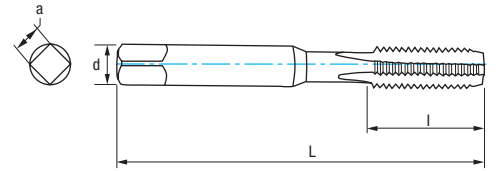

HSS

ISO 529

Tol. 6H



$\alpha$  10° ± 2



Grupo Group-Gruppe **P**

Subgrup. P.1

Grupo Group-Gruppe **K**

Grupo Group-Gruppe **N**  
Subgrup. N.1 - N.3  
N.4 - N.5

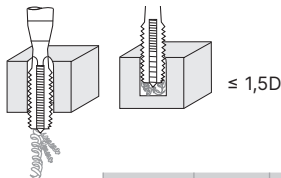

**N°3 Acabado Finishing Finition**

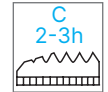
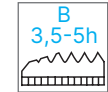

M	P	L mm	l mm	d mm	a mm	Z	N° Art. HSS	€	N° Art. HSS	€	N° Art. HSS	€
M1	0,25	38,50	5,50	2,50	2,00	3	29121		29122		29123	
M1,2	0,25	38,50	5,50	2,50	2,00	3	29124		29125		29126	
M1,4	0,30	40,00	7,00	2,50	2,00	3	29127		29128		29129	
M1,6	0,35	41,00	8,00	2,50	2,00	3	29130		29131		29132	
M1,7	0,35	41,00	8,00	2,50	2,00	3	29133		29134		29159	
M1,8	0,35	41,00	8,00	2,50	2,00	3	29160		29162		29164	
M2	0,40	41,00	8,00	2,50	2,00	3	29171		29172		29175	
M2	0,45	41,00	8,00	2,50	2,00	3	29176		29177		29193	
M2,2	0,45	44,50	9,50	2,80	2,24	3	29195		29196		29197	
M2,3	0,45	44,50	9,50	2,80	2,24	3	29199		29211		29212	
M2,5	0,45	44,50	9,50	2,80	2,24	3	29214		29216		29217	
M2,6	0,45	44,50	9,50	2,80	2,24	3	29218		29234		29277	
MF3	0,35	48,00	11,00	3,15	2,50	3	45629		45644		45647	
M3	0,50	48,00	11,00	3,15	2,50	3	29475		29477		29484	
M3	0,60	48,00	11,00	3,15	2,50	3	29494		29633		29846	
MF3,5	0,35	48,00	11,00	3,15	2,50	3					45650	
M3,5	0,60	50,00	13,00	3,55	2,80	3	29861		29862		29865	
MF4	0,50	53,00	13,00	4,00	3,15	3	45659		45662		45665	
M4	0,70	53,00	13,00	4,00	3,15	3	29866		29867		29872	
M4	0,75	53,00	13,00	4,00	3,15	3	29879		29886		29887	
M4,5	0,75	53,00	13,00	4,00	3,15	3	29889		29890		29892	
MF5	0,50	58,00	16,00	5,00	4,00	3	45668		45671		45698	
MF5	0,75	58,00	16,00	5,00	4,00	3	45701		45705		45744	
M5	0,80	58,00	16,00	5,00	4,00	3	29943		29948		29956	
M5	0,90	58,00	16,00	5,00	4,00	3	29957		29966		29973	
M5,5	0,90	62,00	12,00	5,60	4,50	3	29982		29983		29984	
MF6	0,50	66,00	19,00	6,30	5,00	3	45819		45822		45845	
MF6	0,75	66,00	19,00	6,30	5,00	3	45854		45856		45859	
M6	1,00	66,00	19,00	6,30	5,00	3	29986		29987		30006	
MF7	0,75	66,00	19,00	7,10	5,60	3	45869		45875		45878	
M7	1,00	66,00	19,00	7,10	5,60	3	30007		30009		30010	
MF8	0,50	66,00	19,00	8,00	6,30	3	45884		45890		45893	
MF8	0,75	66,00	19,00	8,00	6,30	3	45902		45904		45917	
MF8	1,00	66,00	19,00	8,00	6,30	3	45931		45934		45935	
M8	1,25	66,00	19,00	8,00	6,30	3	30011		30013		30016	
MF9	0,75	66,00	19,00	9,00	7,10	3					45936	
MF9	1,00	72,00	22,00	9,00	7,10	3	45938		45939		45940	
M9	1,25	72,00	22,00	9,00	7,10	3	30017		30018		30020	
MF10	0,50	73,00	20,00	10,00	8,00	3					45942	
MF10	0,75	73,00	20,00	10,00	8,00	3	46031		46034		46037	
MF10	1,00	80,00	24,00	10,00	8,00	3	46040		46043		46046	
MF10	1,25	80,00	24,00	10,00	8,00	3	46049		46052		46055	
M10	1,50	80,00	24,00	10,00	8,00	3	30021		30063		30064	
MF11	0,75	80,00	22,00	8,00	6,30	4	46058		46061		46067	
MF11	1,00	80,00	22,00	8,00	6,30	4	46070		46075		46078	
MF11	1,25	80,00	22,00	8,00	6,30	4					46089	





M	P	L mm	I mm	d mm	a mm	Z	Nº Art. HSS	€	Nº Art. HSS	€	Nº Art. HSS	€
<b>M11</b>	<b>1,50</b>	80,00	22,00	8,00	6,30	4	30065		30066		30067	
MF12	0,75	80,00	22,00	9,00	7,10	4					46091	
MF12	1,00	80,00	22,00	9,00	7,10	4	46093		46095		46098	
MF12	1,25	89,00	29,00	9,00	7,10	4	46101		46103		46104	
MF12	1,50	89,00	29,00	9,00	7,10	4	46105		46155		46156	
<b>M12</b>	<b>1,75</b>	89,00	29,00	9,00	7,10	4	30068		30069		30070	
MF13	1,50	89,00	29,00	9,00	7,10	4					46158	
MF14	1,00	87,00	22,00	11,20	9,00	4	46159		46161		46162	
MF14	1,25	95,00	30,00	11,20	9,00	4	46164		46165		46167	
MF14	1,50	95,00	30,00	11,20	9,00	4	46168		46169		46170	
<b>M14</b>	<b>2,00</b>	95,00	30,00	11,20	9,00	4	30071		30072		30073	
MF15	1,50	95,00	30,00	11,20	9,00	4			46171		46173	
MF16	1,00	92,00	22,00	12,50	10,00	4	46176		46177		46178	
MF16	1,25	102,00	32,00	12,50	10,00	4					46179	
MF16	1,50	102,00	32,00	12,50	10,00	4	46180		46181		46182	
<b>M16</b>	<b>2,00</b>	102,00	32,00	12,50	10,00	4	30074		30075		30076	
MF18	1,00	97,00	22,00	14,00	11,20	4	46183		46184		46315	
MF18	1,50	112,00	37,00	14,00	11,20	4	46327		46348		46525	
MF18	2,00	112,00	37,00	14,00	11,20	4	46531		46540		46631	
<b>M18</b>	<b>2,50</b>	112,00	37,00	14,00	11,20	4	30077		30078		30080	
MF20	1,00	102,00	22,00	14,00	11,20	4	46901		46823		46898	
MF20	1,50	112,00	37,00	14,00	11,20	4	46919		46925		46931	
MF20	2,00	112,00	37,00	14,00	11,20	4	46940		46967		46976	
<b>M20</b>	<b>2,50</b>	112,00	37,00	14,00	11,20	4	30082		30083		30085	
MF22	1,00	118,00	38,00	16,00	12,50	4			46979		46982	
MF22	1,50	118,00	38,00	16,00	12,50	4	46985		46988		46994	
MF22	2,00	118,00	38,00	16,00	12,50	4	46997		47000		47006	
<b>M22</b>	<b>2,50</b>	118,00	38,00	16,00	12,50	4	30086		30087		30088	
MF24	1,00	130,00	45,00	18,00	14,00	4			47012		47015	
MF24	1,50	130,00	45,00	18,00	14,00	4	47018		47021		47024	
MF24	2,00	130,00	45,00	18,00	14,00	4	47027		47033		47036	
<b>M24</b>	<b>3,00</b>	130,00	45,00	18,00	14,00	4	30089		30090		30091	
MF25	1,50	130,00	45,00	18,00	14,00	4	47198		47273		47276	
MF26	1,50	120,00	35,00	18,00	14,00	4			47279		47282	
MF27	1,50	127,00	37,00	20,00	16,00	4			47288		47300	
MF27	2,00	127,00	37,00	20,00	16,00	4					47435	
<b>M27</b>	<b>3,00</b>	127,00	37,00	20,00	16,00	4	30092		30093		30111	
MF28	1,50	127,00	37,00	20,00	16,00	4			47444		47453	
MF30	1,50	127,00	37,00	20,00	16,00	4			47960		47963	
MF30	2,00	127,00	37,00	20,00	16,00	4			47966		47969	
<b>M30</b>	<b>3,50</b>	127,00	37,00	20,00	16,00	4	30112		30113		30115	
MF32	1,50	137,00	37,00	22,40	18,00	4	48092		48095		48098	
MF33	2,00	137,00	37,00	22,40	18,00	4			48104		48107	
<b>M33</b>	<b>3,50</b>	137,00	37,00	22,40	18,00	4	30118		30120		30125	
MF35	1,50	144,00	39,00	25,00	20,00	4			48110		48113	
MF36	1,50	144,00	39,00	25,00	20,00	4					48140	
MF36	2,00	144,00	39,00	25,00	20,00	4			48149		48152	
MF36	3,00	144,00	39,00	25,00	20,00	4			48161		48164	
<b>M36</b>	<b>4,00</b>	144,00	39,00	25,00	20,00	4	30126		30138		30145	
MF39	3,00	170,00	60,00	28,00	22,40	4			48176		48188	
<b>M39</b>	<b>4,00</b>	170,00	60,00	28,00	22,40	4	30146		30147		30148	
MF40	1,50	149,00	39,00	28,00	22,40	4			48191		48194	
MF42	1,50	149,00	39,00	28,00	22,40	4			48197		48200	
MF42	3,00	149,00	39,00	28,00	22,40	4					48203	
<b>M42</b>	<b>4,50</b>	149,00	39,00	28,00	22,40	4	30149		30150		30151	
MF45	1,50	165,00	45,00	31,50	25,00	4			48206		48209	
<b>M45</b>	<b>4,50</b>	165,00	45,00	31,50	25,00	4	30152		30430		30459	
MF48	1,50	165,00	45,00	31,50	25,00	4					48212	
MF48	2,00	165,00	45,00	31,50	25,00	4					48218	
MF48	3,00	165,00	45,00	31,50	25,00	4					48224	
<b>M48</b>	<b>5,00</b>	187,00	67,00	31,50	25,00	4	30487		30493		30494	
MF50	1,50	165,00	45,00	31,50	25,00	4			48284		48287	
<b>M52</b>	<b>5,00</b>	200,00	70,00	35,50	28,00	4					30495	
<b>M56</b>	<b>5,50</b>	200,00	70,00	35,50	28,00	4					30500	



# Set 3039

## MACHO ÚNICO MANO MÉTRICA / MÉTRICA FINA NORMA ISO

ISO Standard Metric / Metric Fine Hand Single Tap

Taraud à main unique métrique / métrique pas fin norme ISO

Ref. 3039 + 1015 Zirkonio



14 Pcs

Cont.	Nº Art. Zirkonio	€
<b>Machos / Taps / Tarauds</b> ISO 529: M3-M4-M5-M6-M8-M10-M12 	26020	
<b>Brocas / Drill Bits / Forets</b> Zirkonio: 2,5-3,3-4,2-5,0-6,8-8,5-10,2		

# Ref. 3103

## MACHO RECTO MÁQUINA UNC NORMA ISO 529

ISO 529 Norm Standard UNC Machine Straight Tap

Taraud droit machine UNC norme ISO 529

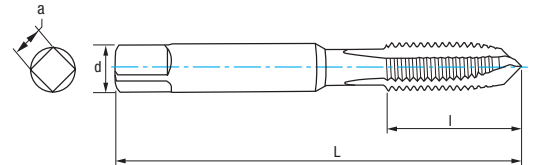

HSS	ISO 529	B 3,5-5h	C 2-3h	Tol. 6H	GUN	$\alpha$ 10-12°	60°
-----	---------	----------	--------	---------	-----	-----------------	-----

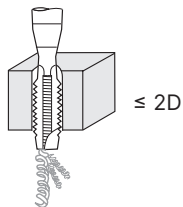

$Avance f = P$  (Paso - Pitch - Pas)  
 $V_f$  (mm/min.) = r.p.m. x f  
 $r.p.m. = \frac{V_c \times 1.000}{\pi \times \phi}$

Material		Vc (m/min)
Grupo	Sub.	HSS
P	P.1	6-10
N	N.1	5-8
	N.3	15-35
	N.4	14-20



UNC	Hilos Threads Filets	L mm	l mm	d mm	a mm	Z	Nº Art. 5% Co	€	Nº Art. 5% Co	€
UNC N°1	64	41	8	2,50	2,00	3	62989		62990	
UNC N°2	56	45	10	2,80	2,24	3	62991		62992	
UNC N°3	48	45	10	2,80	2,24	3	62994		62995	
UNC N°4	40	48	11	3,15	2,50	3	62996		62997	
UNC N°5	40	48	11	3,15	2,50	3	62998		62999	
UNC N°6	32	50	13	3,55	2,80	3	63000		63001	
UNC N°8	32	53	13	4,50	3,55	3	63003		63004	
UNC N°10	24	58	16	5,00	4,00	3	63006		63007	
UNC N°12	24	62	17	5,60	4,50	3	63009		63012	
UNC 1/4	20	66	19	6,30	5,00	3	63016		63018	
UNC 5/16	18	72	22	8,00	6,30	3	63019		63021	
UNC 3/8	16	80	24	10,00	8,00	3	63022		63027	
UNC 7/16	14	85	25	8,00	6,30	3	63028		63030	
UNC 1/2	13	89	29	9,00	7,10	3	63031		63033	
UNC 9/16	12	95	30	11,20	9,00	3	63034		63036	
UNC 5/8	11	102	32	12,50	10,00	3	63038		63039	
UNC 3/4	10	112	37	14,00	11,20	3	63040		63042	
UNC 7/8	9	118	38	16,00	12,50	3	63043		63045	
UNC 1"	8	130	45	18,00	14,00	3	63046		63047	
UNC 1"1/8	7	138	48	20,00	16,00	4	63048		63049	
UNC 1"1/4	7	151	51	22,40	18,00	4	63051		63052	
UNC 1"3/8	6	162	57	25,00	20,00	4	63054		63057	
UNC 1"1/2	6	170	60	28,00	22,40	4	63058		63060	
UNC 1"3/4	5	187	67	31,50	25,00	4	63061		63063	
UNC 2"	4	200	70	35,50	28,00	4	63064		63066	





Ref. **3141**

**MACHO LAMINACIÓN ALTO RENDIMIENTO UNC/UNF**  
 UNC/UNF High Performance **Cold Forming** Machine Tap  
 Taraud machine **réfouleur** haut rendement UNC/UNF

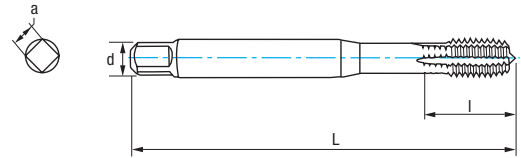

HSSE 5%Co	TIALN + TIN	DIN 371 < 7/16	DIN 376 ≥ 7/16	C 2-3h		Tol. 2BX		
--------------	-------------------	----------------------	----------------------	-----------	--	-------------	--	--

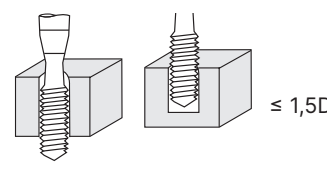

Avance  $f = P$  (Paso - Pitch - Pas)  
 $V_f$  (mm/min.) = r.p.m. x f  
 $r.p.m. = \frac{V_c \times 1.000}{\pi \times \phi}$

Material		Vc (m/min.)
Grupo	Sub.	TIALN-TIN
P	P.1	10-30
	P.2	10-30
	P.3	8-15
	P.5	10-25
M		10-25
N	N.1	20-40
	N.2	20-40
	N.3	20-40
	N.4	20-40
	N.5	20-40

UNC	Hilos Threads	Filets	L mm	l mm	d mm	a mm	Nº Art. 5% Co	€
UNC N°5	40		56	7	3,5	2,7	10812	
UNC N°6	32		56	6	4,0	3,0	10818	
UNC N°8	32		63	7	4,5	3,4	10821	
UNC N°10	24		70	8	6,0	4,9	10824	
UNC N°12	24		80	10	6,0	4,9	10828	
UNC 1/4	20		80	13	7,0	5,5	10829	
UNC 5/16	18		90	13	8,0	6,2	10830	
UNC 3/8	16		100	15	10,0	8,0	10848	
UNC 7/16	14		100	15	8,0	6,2	10850	
UNC 1/2	13		110	18	9,0	7,0	10851	
UNC 5/8	11		110	20	12,0	9,0	10860	



UNF	Hilos Threads	Filets	L mm	l mm	d mm	a mm	Nº Art. 5% Co	€
UNF N°5	44		56	7,0	3,5	2,7	10861	
UNF N°6	40		56	6,0	4,0	3,0	10863	
UNF N°8	36		63	7,0	4,5	3,4	10864	
UNF N°10	32		70	8,0	6,0	4,9	10866	
UNF N°12	28		80	10,0	6,0	4,9	10873	
UNF 1/4	28		80	10,0	6,0	4,9	10887	
UNF 5/16	24		90	13,0	8,0	6,2	10888	
UNF 3/8	24		100	15,0	10,0	8,0	10891	
UNF 7/16	20		100	15,0	8,0	6,2	10892	
UNF 1/2	20		110	15,0	9,0	7,0	10893	
UNF 5/8	18		110	15,0	12,0	9,0	10896	
UNF 3/4	16		120	17,0	14,0	11,0	10905	

Ref. 3141 bajo demanda / upon request / sur demande

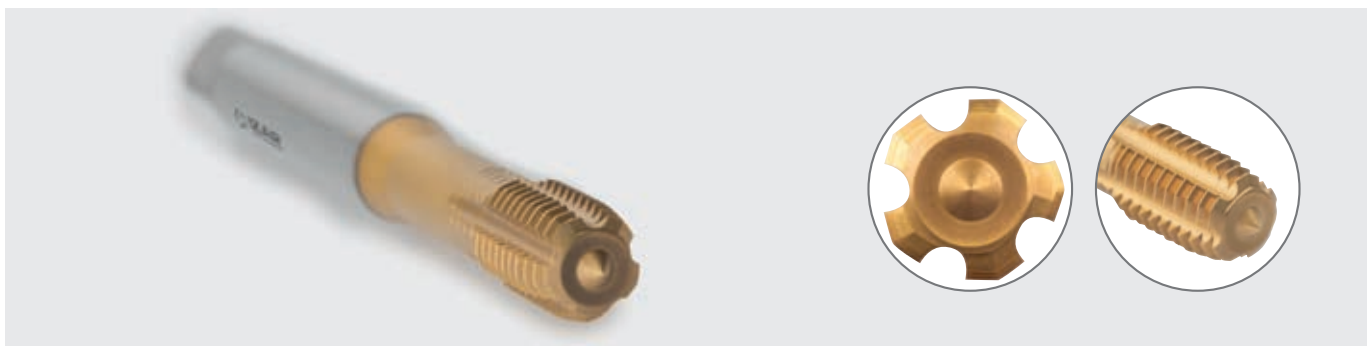

Ref. **3123**

**MACHO RECTO MÁQUINA UNF NORMA ISO 529**  
 ISO 529 Norm Standard UNF Machine Straight Tap  
 Taraud droit machine UNF norme ISO 529

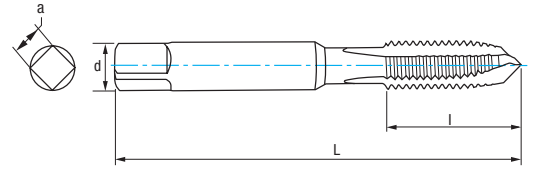

HSS	ISO 529	B 3,5-5h	C 2-3h	Tol. 6H	GUN	$\alpha$ 10-12°	60°
-----	---------	-------------	-----------	------------	-----	--------------------	-----

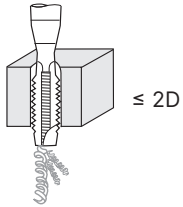

Material		Vc (m/min)
Grupo	Sub.	HSS
P	P.1	6-10
N	N.1	5-8
	N.3	15-35
	N.4	14-20

Avance  $f = P$  (Paso - Pitch - Pas)  
 $V_f$  (mm/min.) = r.p.m. x  $f$   
 $r.p.m. = \frac{V_c \times 1.000}{\pi \times \phi}$

UNF	Hilos Threads Filets	L mm	l mm	d mm	a mm	Z	B 3,5-5h		C 2-3h	
							N° Art. HSS	€	N° Art. HSS	€
UNF N°0	80	41	8	2,50	2,00	3	63067	€	66203	€
UNF N°1	72	41	8	2,50	2,00	3	63069	€	66205	€
UNF N°2	64	45	10	2,80	2,24	3	63070	€	66398	€
UNF N°3	56	45	10	2,80	2,24	3	84231	€	84232	€
UNF N°4	48	48	11	3,15	2,50	3	63072	€	66410	€
UNF N°5	44	48	11	3,15	2,50	3	63075	€	66413	€
UNF N°6	40	50	13	3,55	2,80	3	63076	€	66509	€
UNF N°8	36	53	13	4,50	3,55	3	63079	€	66512	€
UNF N°10	32	58	16	5,00	4,00	3	63112	€	66566	€
UNF N°12	28	62	17	5,60	4,50	3	63171	€	66596	€
UNF 1/4	28	66	19	6,30	5,00	3	63172	€	66722	€
UNF 5/16	24	72	22	8,00	6,30	3	63173	€	66728	€
UNF 3/8	24	80	24	10,00	8,00	3	63174	€	67163	€
UNF 7/16	20	85	25	8,00	6,30	3	63175	€	67169	€
UNF 1/2	20	89	29	9,00	7,10	3	63177	€	67349	€
UNF 9/16	18	95	30	11,20	9,00	3	63180	€	67358	€
UNF 5/8	18	102	32	12,50	10,00	3	63181	€	67359	€
UNF 3/4	16	112	37	14,00	11,20	3	63184	€	67361	€
UNF 7/8	14	118	38	16,00	12,50	3	63213	€	67364	€
UNF 1"	12	130	45	18,00	14,00	3	63326	€	67370	€
UNF 1"1/8	12	127	37	20,00	16,00	4	63389	€	67373	€
UNF 1"1/4	12	137	37	22,40	18,00	4	63392	€	67376	€
UNF 1"3/8	12	144	39	25,00	20,00	4	63446	€	67394	€
UNF 1"1/2	12	149	39	28,00	22,40	4	64121	€	67403	€



Ref. **3560**

**COJINETE MANO HEXAGONAL MÉTRICA / MÉTRICA FINA**

Metric / Metric Fine HEX Hand Die

Filière à main hexagonale métrique / métrique pas fin

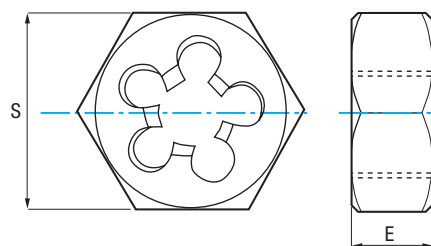

HSS	DIN 382		Tol. 6g
-----	---------	--	---------

M/MF	P	S mm	E mm	N° Art. HSS	€
MF3	0,35	19	5	84244	
<b>M3</b>	<b>0,50</b>	19	5	84245	
<b>M3,5</b>	<b>0,60</b>	19	5	84246	
MF4	0,50	19	5	84247	
<b>M4</b>	<b>0,70</b>	19	5	84248	
<b>M4,5</b>	<b>0,75</b>	19	7	84249	
MF5	0,50	19	7	84250	
<b>M5</b>	<b>0,80</b>	19	7	84251	
MF6	0,75	19	7	84252	
<b>M6</b>	<b>1,00</b>	19	7	84253	
MF7	0,75	22	9	84254	
<b>M7</b>	<b>1,00</b>	22	9	84255	
MF8	0,75	22	9	84256	
MF8	1,00	22	9	84259	
<b>M8</b>	<b>1,25</b>	22	9	84260	
MF9	1,00	22	9	84261	
<b>M9</b>	<b>1,25</b>	22	9	84262	
MF10	1,00	27	11	84263	
<b>M10</b>	<b>1,50</b>	27	11	84264	
MF11	1,00	27	11	84266	
<b>M11</b>	<b>1,50</b>	27	11	84267	
MF12	1,00	36	10	84268	
MF12	1,25	36	10	84269	
MF12	1,50	36	10	84270	
<b>M12</b>	<b>1,75</b>	36	14	84271	
MF14	1,00	36	10	84272	
MF14	1,25	36	10	84273	
MF14	1,50	36	10	84274	
<b>M14</b>	<b>2,00</b>	36	14	84275	
MF16	1,50	41	14	84276	

M/MF	P	S mm	E mm	N° Art. HSS	€
<b>M16</b>	<b>2,00</b>	41	18	84277	
MF18	1,50	41	14	84278	
MF18	2,00	41	14	84279	
<b>M18</b>	<b>2,50</b>	41	18	84281	
MF20	1,50	41	14	84283	
MF20	2,00	41	14	84282	
<b>M20</b>	<b>2,50</b>	41	18	84284	
MF22	1,50	50	16	84285	
MF22	2,00	50	16	84286	
<b>M22</b>	<b>2,50</b>	50	16	84287	
MF24	1,50	50	16	84288	
MF24	2,00	50	16	84289	
<b>M24</b>	<b>3,00</b>	50	22	84290	
MF26	1,50	60	18	84291	
MF27	1,50	60	18	84292	
MF27	2,00	60	18	84293	
<b>M27</b>	<b>3,00</b>	60	25	84294	
MF28	1,50	60	18	84295	
MF30	1,50	60	18	84296	
MF30	2,00	60	18	84297	
<b>M30</b>	<b>3,50</b>	60	25	84298	
MF32	1,50	60	18	84299	
MF33	1,50	60	18	84300	
MF33	2,00	60	18	84301	
<b>M33</b>	<b>3,50</b>	60	25	84302	
MF35	1,50	60	18	84303	
MF36	1,50	60	18	84304	
MF36	2,00	60	18	84305	
MF36	3,00	60	18	84306	
<b>M36</b>	<b>4,00</b>	60	25	84307	



- |  |   |   |
|--|---|---|
| <ul style="list-style-type: none"> <li>• Para uso con llave fija, ajustable o de vaso</li> <li>• Ideal para espacios limitados</li> <li>• Recomendado para reparar roscas</li> </ul> | <ul style="list-style-type: none"> <li>• For use with a fixed, extendable, or socket wrench</li> <li>• Ideal for tight spaces</li> <li>• Recommended for rethreading threads</li> </ul> | <ul style="list-style-type: none"> <li>• Pour une utilisation avec une clé fixe, une clé extensible ou à douille</li> <li>• Idéal pour les espaces restreints</li> <li>• Recommandé pour réparer les filetages</li> </ul> |
|--|---|---|



Ref. **9444**  
**IZARCUT**

**FRESA FRONTAL METAL DURO 4Z CREST CUT ALTO RENDIMIENTO**  
 High Performance **Crest Cut** 4Z Carbide End Mill  
 Fraise Carbure 4Z **Crest Cut** haute performance

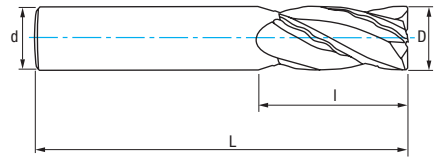

<b>MD/HM</b> Carbure Grano MG	<b>CROMAX</b>	DIN 6528 N		4 Z		DIN 6535 HA	Tol. D (e8) d (h6)		
-------------------------------------	---------------	---------------	--	-----	--	----------------	--------------------------	--	--

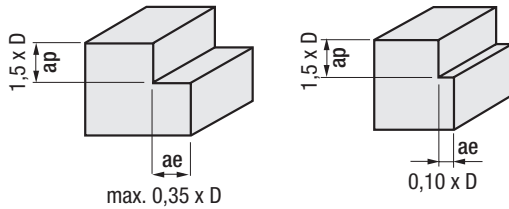

Material		Vc (m/min)	Avances fz/rev. (mm/z) - Feed - Pas				
Grupo	Sub.	<b>CROMAX</b>	Ø8	Ø 10	Ø 12	Ø 16	Ø 20
<b>P</b>	<b>P.2</b>	112-150	0,040	0,055	0,065	0,080	0,100
	<b>P.3</b>	60-130	0,035	0,040	0,050	0,060	0,075
	<b>P.5</b>	50-80	0,035	0,035	0,050	0,120	0,150
<b>M</b>		100-130	0,025	0,025	0,040	0,100	0,120
<b>K</b>	<b>K.1</b>	60-80	0,040	0,055	0,065	0,080	0,100
	<b>K.2</b>	40-60	0,020	0,025	0,030	0,040	0,050
<b>S</b>		90-130	0,040	0,055	0,065	0,080	0,100
<b>N</b>	<b>N.1</b>	140-350	0,050	0,060	0,075	0,080	0,125
	<b>N.2</b>	140-350	0,050	0,060	0,075	0,080	0,125

$r.p.m. = \frac{Vc \times 1000}{\pi \times \phi}$       **K** = Coeficiente corrección  
 Correction coefficient  
 Coéfcient correction

$Vf (mm/min.) = r.p.m. \times Z \times fz \times K$

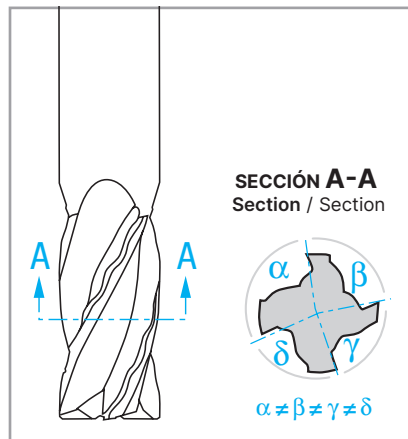

D mm	d mm	L mm	l mm	Z	N° Art. CROMAX	€
10,00	10,00	72	22	4	28759	
12,00	12,00	83	26	4	28760	
16,00	16,00	92	32	4	28761	



**DIN 6535 HB**  
 Bajo demanda / upon request / sur demande

- |  |  |   |
|--|--|---|
| <ol style="list-style-type: none"> <li>1. Desbaste y Acabado con la misma herramienta</li> <li>2. Mayor profundidad de corte (hasta un 40%)</li> <li>3. Excelente control de viruta, especialmente sobre <b>Titanio</b></li> <li>4. Excelente calidad superficial</li> </ol> | <ol style="list-style-type: none"> <li>1. Roughing &amp; Finishing with the same tool</li> <li>2. Higher cutting depth (up to 40%)</li> <li>3. Excellent chipping control, especially for <b>titanium</b></li> <li>4. Excellent surface quality</li> </ol> | <ol style="list-style-type: none"> <li>1. Ebauche et finition avec le même outil</li> <li>2. Meilleure proffondeur de coupe (jusqu'au 40%)</li> <li>3. Excellent contrôle des copeaux, surtout pour le <b>titane</b></li> <li>4. Excellente qualité de surface</li> </ol> |
|--|--|---|

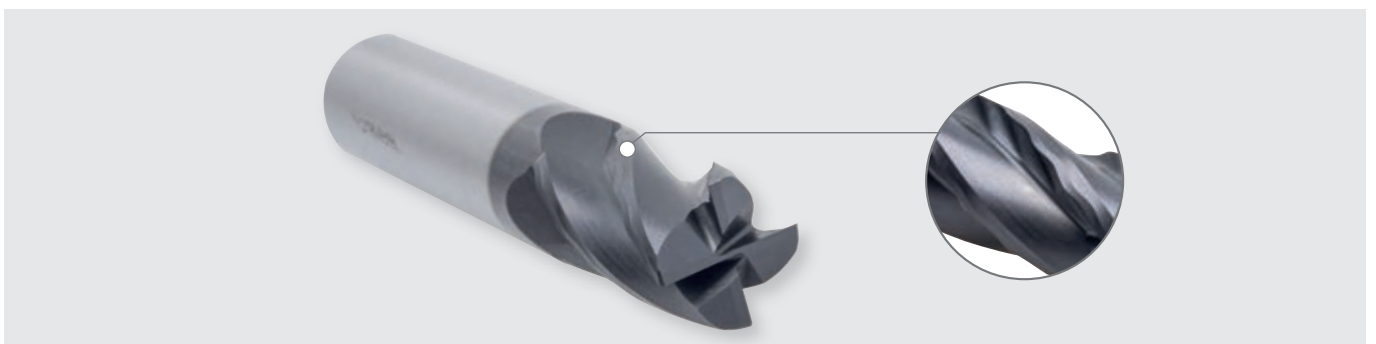

# IRIS, UN PASO MÁS EN EL MECANIZADO DE MATERIALES NO FERROSOS

IRIS, the Next Level of Machining Non-Ferrous Materials

IRIS, le niveau suivant dans l'usinage des matériaux non ferreux

IRIS

**Dureza extrema**  
Extreme Hardness  
Extrême dureté

**Super suave**  
Super Smoothness  
Super lissage

**Recubrimiento super fino**  
Super Thin Coating  
Revêtement ultra-fin

## MEJORA DE PROPIEDADES Property Enhancement Amélioration des propriétés

- Excelente adhesión
- Superficies más suaves
- Mayores durezas
- Excellent adhesion
- Smoother surfaces
- Increased hardness
- Excellente adhérence
- Surfaces plus lisses
- Dureté accrue



**Permite el reacondicionamiento**  
Enable Reconditioning  
Permettre le reconditionnement

H<sub>T</sub> (GPa)

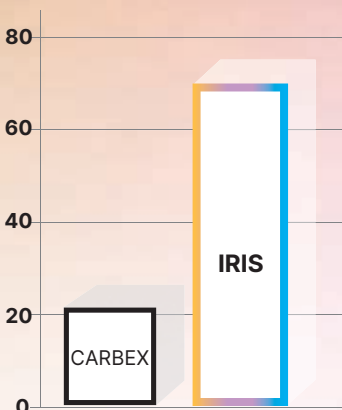

Base Carbono ta-C Carbon ta-C Base Base Carbone ta-C	
Dureza / Hardness / Dureté HV(0,05)	> 6500
Oxidación / Oxidation / Oxidation	> 500°C
Coefficiente Fricción Rubbing Coefficient/Coefficient Friction	0,30-1,50
Color / Colour / Couleur: Arco Iris / Rainbow / Arc-en-ciel	

Con una dureza de 60-70 GPa, IRIS alcanza más del doble de dureza que el recubrimiento actual CARBEX

With a hardness of 60-70 GPa, IRIS achieves more than double the hardness of the current coating, CARBEX

Avec une dureté de 60-70 GPa, IRIS atteint plus du double de la dureté du revêtement actuel CARBEX

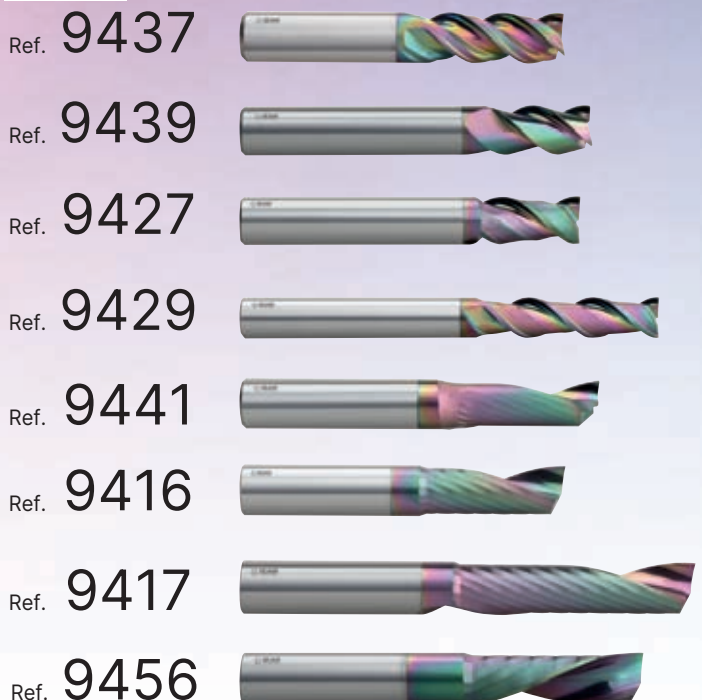





## FRESAS DE ROSCAR

### Thread Mills

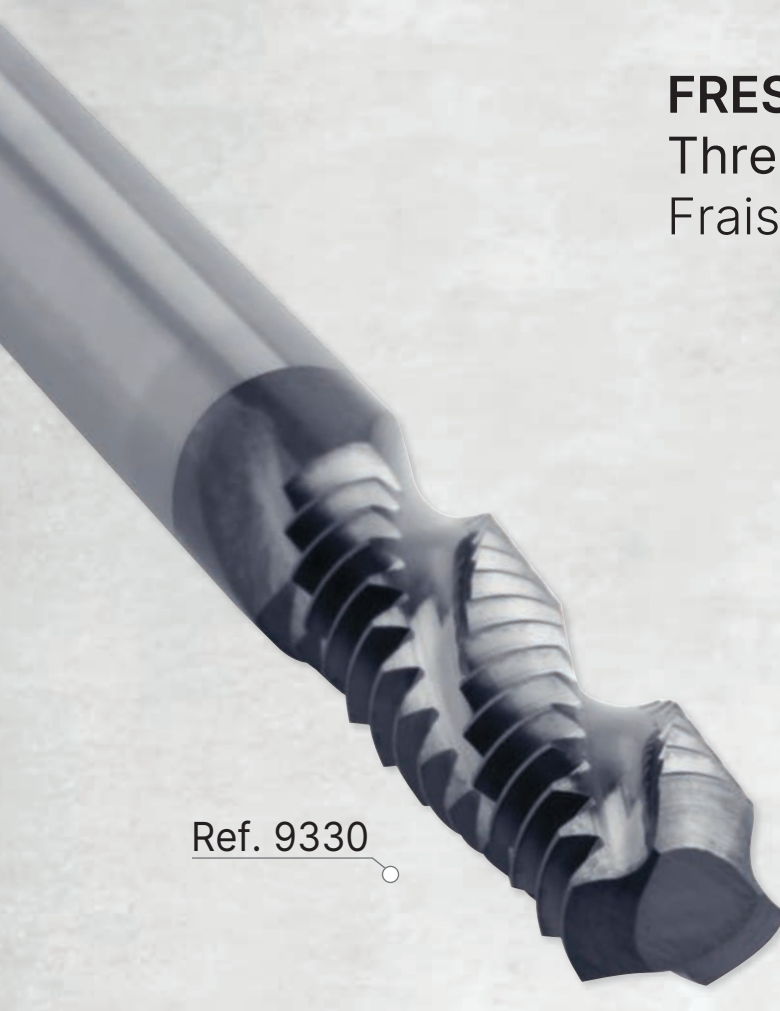
### Fraises à fileter



Ref. 9330



Ref. 9333

El fresado de roscas es un proceso versátil y rentable para el corte de una gran variedad de roscas, piezas y materiales a mecanizar en la misma máquina.

Se puede utilizar una sola fresa para roscar distintos agujeros con el mismo paso. Esto reduce los costes de sus herramientas y acorta el tiempo de cambio de herramienta. Nuestras fresas de roscar se pueden utilizar para crear roscas tanto internas como externas.

Thread milling is a versatile and cost-effective process for cutting a wide variety of threads, parts and materials to be machined on the same machine. A single threading mill can be used to make a wide range of holes with the same pitch. This lowers the cost of your tools and reduces the tool change time. Our threading mills can be used to make both internal and external threads.

Le fraisage de filets est un processus polyvalent et rentable pour la coupe d'une grande variété de filetages, de pièces et de matériaux à usiner sur la même machine.

Une seule fraise à fileter peut être utilisée pour différents trous avec le même pas. Cela réduit les coûts d'outillage et le temps de changement d'outil. Nos fraises à fileter peuvent être utilisées pour créer à la fois des filetages internes et externes.

#### DISPONIBLE CON REFRIGERACIÓN INTERNA

Available with internal cooling  
Disponible avec lubrification interne



Tanto la ref. 9330 como la ref. 9333 están disponibles con refrigeración interna. El refrigerante lubrica, elimina virutas y reduce el calor. Esto da como resultado una mayor vida útil de la herramienta y una mayor productividad.

Both ref. 9330 and ref. 9333 are available with internal cooling. The coolant lubricates, removes chips and reduces heat. This results in higher tool life and more productivity.

Les références 9330 et 9333 sont toutes les deux disponibles avec un système de refroidissement interne. Le liquide de refroidissement lubrifie, évacue les copeaux et réduit la chaleur. Cela se traduit par une durée de vie plus longue de l'outil et une productivité accrue.

Ref. **9330**

**FRESA DE ROSCAR MULTIPASO**  
Multi-Pitch Threading Mill  
Fraise à fileter multi-pas

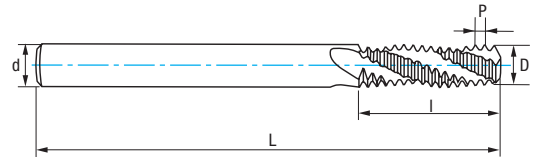

<b>MD/HM</b> Carbure Micrograno	<b>ALTIN</b>	IZAR Std.	3-4 Z	30°	DIN 6535 HA	Tol. D (f7) d (h7)
---------------------------------------	--------------	--------------	-------	-----	----------------	--------------------------

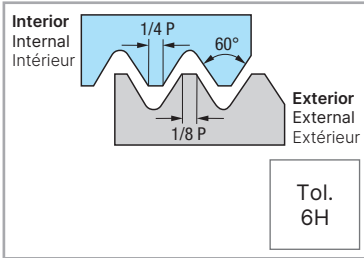

Material		Vc (m/min)
Grupo	Sub.	ALTIN
P	P.1	50-75
	P.2	50-75
	P.3	40-70
M		20-40
K	K.1	50-100
S	Ti6Al4V	30-60
	Inconel 718	15-30
N	N.1	50-100
	N.2	50-100
	N.3	50-100
	N.4	60-130
	N.5	60-130
	N.6	50-100
H	<50HRC	15-30

Avances fz/rev. (mm/z) - Feed - Pas							
M4	M5	M6	M8	M10	M12	M16	M20
0,02-0,04		0,03-0,05				0,05-0,10	

$$r.p.m. = \frac{Vc \times 1.000}{\pi \times \phi}$$

$$Vf (mm/min.) = r.p.m. \times Z \times fz \times K$$

K = Coeficiente corrección  
Correction coefficient  
Coefficient correction



Sin refrigeración  
Without coolant  
Sans refroidissement



Con refrigeración  
With coolant  
Avec refroidissement

M	P	D mm	d mm	L mm	l mm	Z		N° Art. ALTIN	€	N° Art. ALTIN	€
4	0,70	3,10	6	64	9,00	3	1	84642		84643	
5	0,80	4,00	6	64	11,00	3	1	84646		84654	
6	1,00	4,50	6	64	13,50	3	1	84647		84655	
8	1,25	6,00	6	64	18,00	3	1	84648		84656	
10	1,50	7,50	8	64	22,00	3	1	84649		84657	
12	1,75	9,50	10	70	26,00	4	1	84650		84658	
14	2,00	10,00	10	70	30,00	4	1	84651		84659	
16	2,00	12,00	12	83	34,00	4	1	84652		84660	
20	2,50	16,00	16	100	42,00	4	1	84653		84661	

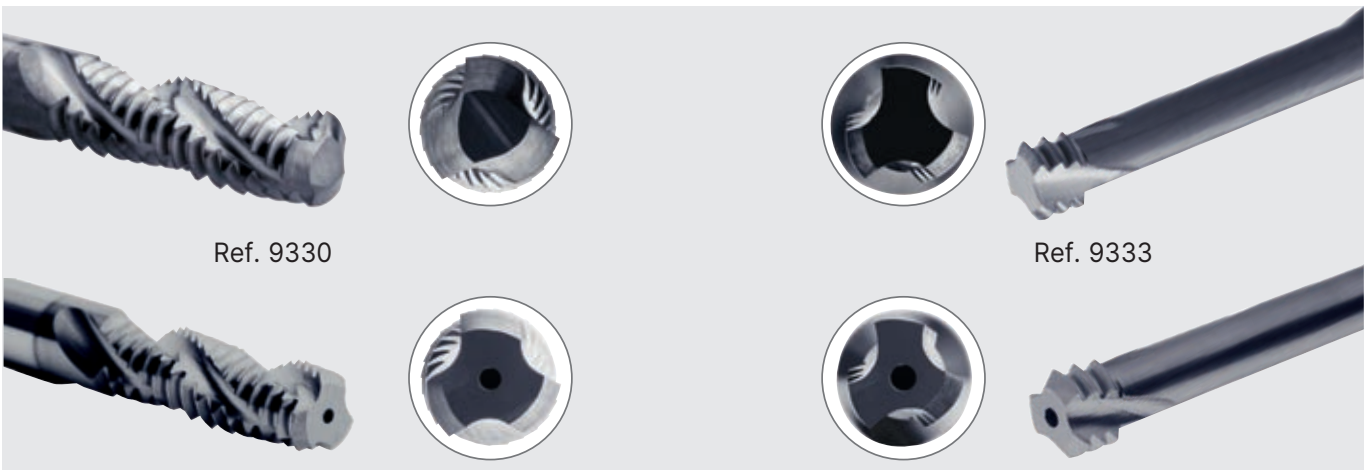

Ref. **9333**

**FRESA DE ROSCAR 3 PASOS**  
3-Pitch Threading Mill  
Fraise à fileter 3-pas

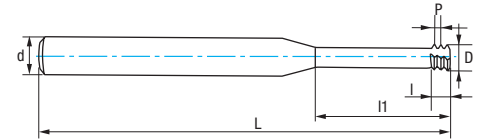

**MD/HM**  
Carbure  
Micrograno

**ALTIN**

IZAR  
Std.

3-4 Z

15°

DIN  
6535 HA

Tol.  
D (f7)  
d (h7)

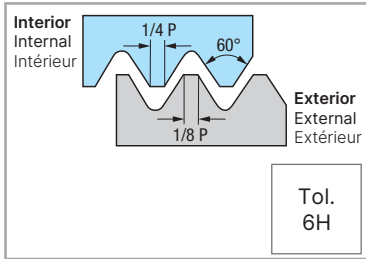

Material		Vc (m/min)
Grupo	Sub.	ALTIN
P	P.1	50-75
	P.2	50-75
	P.3	40-70
M		35-50
K	K.1	50-100
S	Ti6Al44V	30-60
	Inconel 718	15-30
N	N.1	50-100
	N.2	50-100
	N.3	50-100
	N.4	60-130
	N.5	60-130
	N.6	50-100
H	<50HRC	15-30

Avances fz/rev. (mm/z) - Feed - Pas				
M1,6-M2,5	M3-M5	M6	M8-M16	M20-M36
0,01-0,04	0,02-0,05	0,03-0,06	0,03-0,07	0,05-0,10

$$r.p.m. = \frac{Vc \times 1.000}{\pi \times \phi}$$

**K =** Coeficiente corrección  
Correction coefficient  
Coefficient correction

$$Vf \text{ (mm/min.)} = r.p.m. \times Z \times fz \times K$$

**Sin refrigeración**  
Without coolant  
Sans refroidissement

**Con refrigeración**  
With coolant  
Avec refroidissement

M	P	D mm	d mm	L mm	l mm	l1 mm	Z		N° Art. ALTIN	€	N° Art. ALTIN	€
1,6	0,35	1,20	6	64	1,10	4,80	3	1	84644			
1,6	0,35	1,20	6	64	1,10	6,40	3	1	84662			
1,6	0,35	1,20	6	64	1,10	8,00	3	1	84663			
1,8	0,35	1,40	6	64	1,10	5,40	3	1	84664			
1,8	0,35	1,40	6	64	1,10	7,20	3	1	84665			
1,8	0,35	1,40	6	64	1,10	9,00	3	1	84666			
2	0,40	1,50	6	64	1,00	6,00	3	1	84667			
2	0,40	1,50	6	64	1,20	8,00	3	1	84668			
2	0,40	1,50	6	64	1,20	10,00	3	1	84669			
2,5	0,45	1,90	6	64	1,40	7,50	3	1	84670			
2,5	0,45	1,90	6	64	1,40	10,00	3	1	84671			
2,5	0,45	1,90	6	64	1,40	12,50	3	1	84672			
3	0,50	2,40	6	64	1,50	9,50	3	1	84673		84645	
3	0,50	2,40	6	64	1,50	12,00	3	1	84674		84704	
3	0,50	2,40	6	64	1,50	15,00	3	1	84675		84705	
4	0,70	3,10	6	64	2,10	12,50	3	1	84676		84706	
4	0,70	3,10	6	64	2,10	16,00	3	1	84677		84707	
4	0,70	3,10	6	64	2,10	20,00	3	1	84678		84708	
5	0,80	4,00	6	64	2,40	16,00	3	1	84679		84709	
5	0,80	4,00	6	64	2,40	20,00	3	1	84680		84710	
5	0,80	4,00	6	64	2,40	25,00	3	1	84681		84711	
6	1,00	4,50	6	64	3,00	20,00	3	1	84683		84712	
6	1,00	4,50	6	70	3,00	24,00	3	1	84684		84713	
6	1,00	4,50	6	70	3,00	30,00	3	1	84685		84714	
8	1,25	6,00	6	64	3,80	24,00	4	1	84686		84715	
8	1,25	6,00	6	78	3,80	32,00	4	1	84687		84716	
8	1,25	6,00	6	78	3,80	40,00	4	1	84688		84717	
10	1,50	7,50	8	78	4,50	33,00	4	1	84689		84718	
10	1,50	7,50	8	89	4,50	40,00	4	1	84690		84719	
10	1,50	7,50	8	89	4,50	50,00	4	1	84691		84720	
12	1,75	9,50	10	89	5,30	38,00	4	1	84692		84726	
12	1,75	9,50	10	110	5,30	48,00	4	1	84693		84727	
12	1,75	9,50	10	110	5,30	60,00	4	1	84694		84728	
16	2,00	12,00	12	100	6,00	50,00	4	1	84695		84729	
16	2,00	12,00	12	130	6,00	64,00	4	1	84696		84730	
16	2,00	12,00	12	130	6,00	80,00	4	1	84697		84731	
20	2,50	16,00	16	102	7,10	50,00	4	1	84699		84732	
24	3,00	18,00	18	102	8,60	50,00	4	1	84700		84733	
30	3,50	20,00	20	120	10,50	60,00	4	1	84701		84734	
36	4,00	20,00	20	120	11,00	60,00	4	1	84702		84735	



# INFORMACIÓN TÉCNICA FRESAS DE ROSCAR

Technical Information Thread Mills

Information technique fraises à fileter

## MÉTODO DE ROSCADO CON REF. 9330

Threading Method with Ref. 9330 - Méthode de taraudage avec Réf. 9330

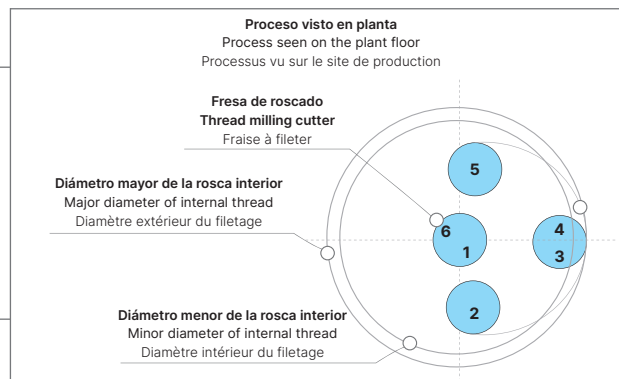
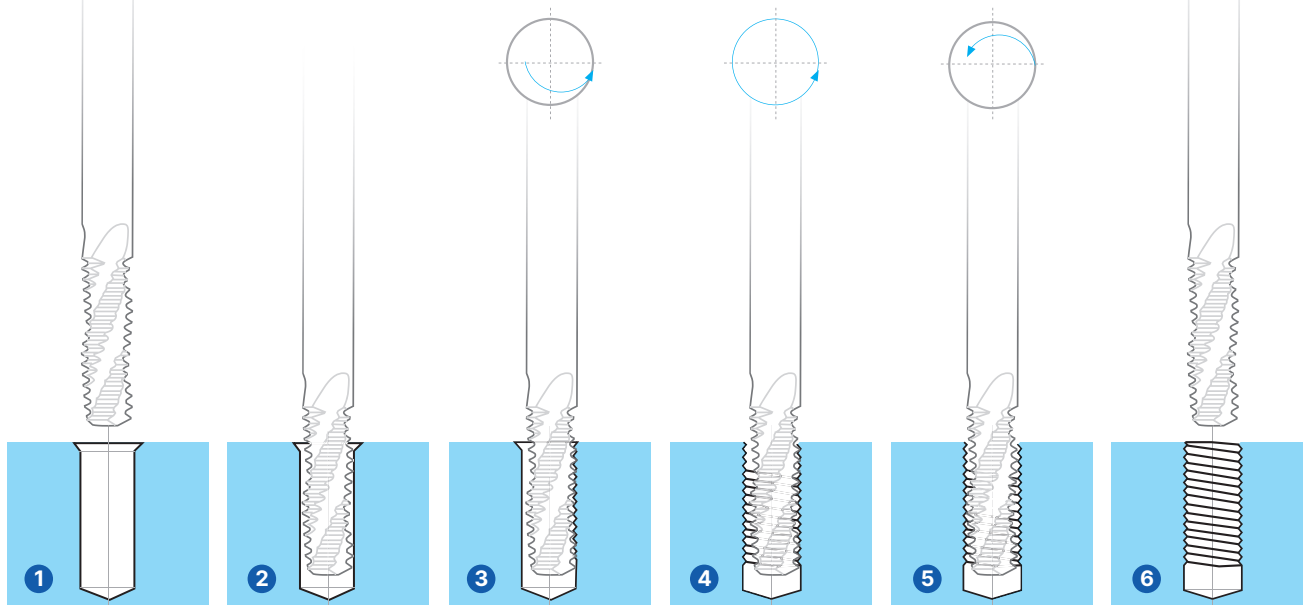

## MÉTODO DE ROSCADO CON REF. 9333

Threading Method with Ref. 9333 - Méthode de taraudage avec Réf. 9333

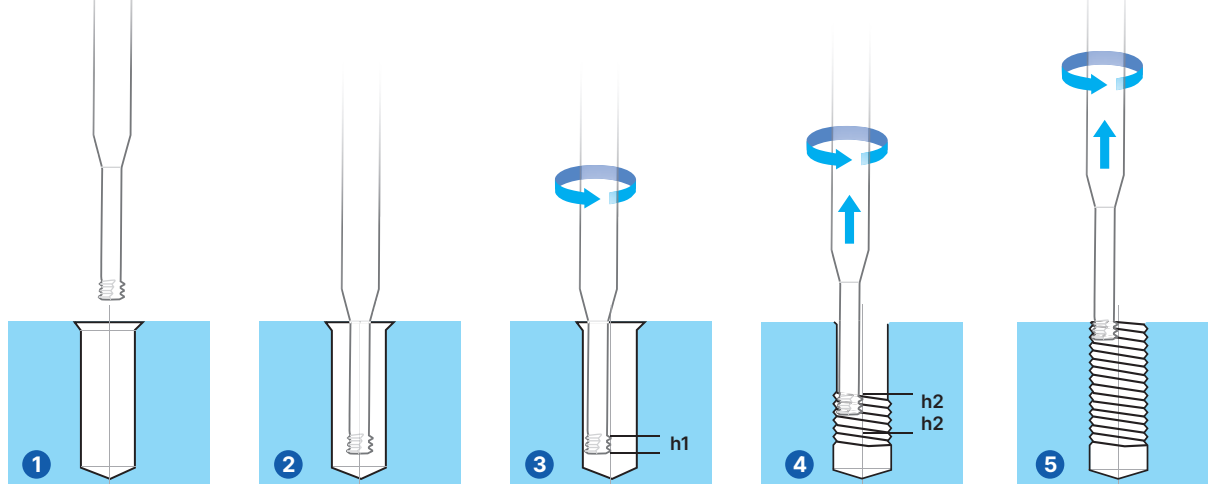

Nota:  
Valor h2:

1. Para mecanizado de uso general  
h2 = 3 Pasos
2. Para mecanizado de materiales termostresistentes (S) o endurecidos (H)  
h2 = 1 Paso

Nota:  
Value h2:

1. For general-purpose machining  
h2 = 3 Pitch
2. For machining heat-resistant (S) or hardened (H) materials  
h2 = 1 Pitch

Nota:  
Valeur h2 :

1. Pour l'usinage général  
h2 = 3 Pas
2. Pour l'usinage de matériaux résistants à la chaleur (S) ou durcis (H)  
h2 = 1 Pas





# BROCAS DE CABEZA INTERCAMBIABLE

Drill Bits With Interchangeable Heads

Forets à tête interchangeable

Ref. **8380** Ref. **8381**

**ALTO AVANCE**  
High Feed  
Avance élevée

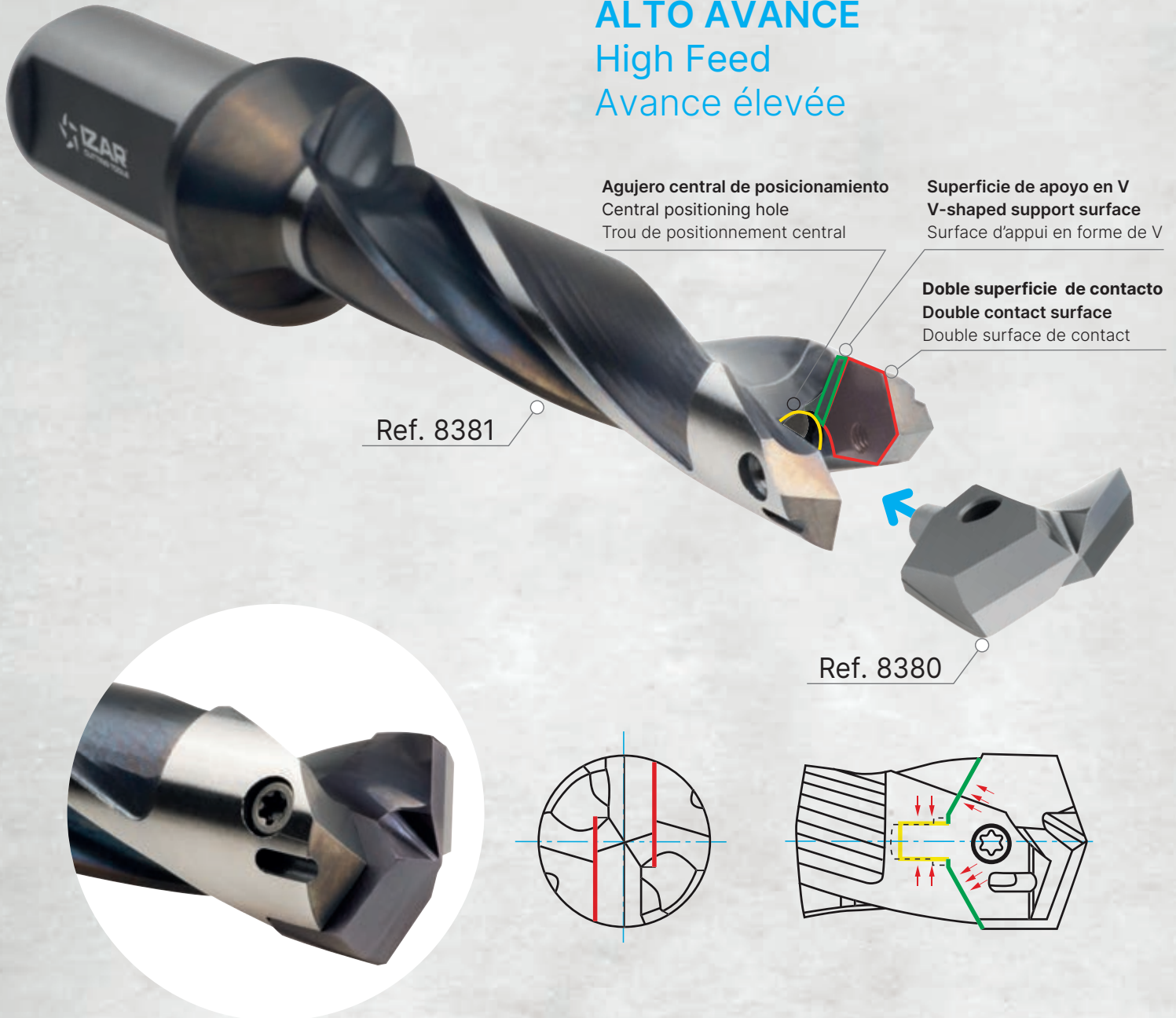

La estructura de posicionamiento triple, presenta una fuerza de conexión y una precisión de posicionamiento extraordinarias, y un diseño geométrico óptimo contribuyen a su excelente velocidad de perforación y durabilidad. Debido a la cabeza intercambiable, se puede lograr una combinación flexible de insertos para varias aplicaciones y soportes de diferentes longitudes, satisfaciendo así las necesidades de diferentes materiales a mecanizar, diferentes profundidades de perforación y otras aplicaciones, minimizando la inversión en herramientas.

The triple positioning structure, featuring outstanding connection strength and positioning accuracy, and an optimal geometrical design contribute to its excellent drilling speed and durability. Due to the interchangeable head, a flexible combination of inserts for various applications and holders of different lengths can be achieved, thus meeting the needs of different materials to be machined, different drilling depths and other applications, minimising the investment in tools.

La structure de positionnement triple, caractérisée par une force de connexion et une précision de positionnement exceptionnelles, ainsi qu'un dessin géométrique optimal contribuent à l'excellente vitesse de perçage et à la durabilité. Grâce à la tête interchangeable, il est possible de combiner de manière flexible des plaquettes pour diverses applications et des supports de différentes longueurs, ce qui permet de répondre aux besoins des différents matériaux à usiner, des différentes profondeurs de perçage et d'autres applications, tout en minimisant l'investissement en termes d'outils.



Ref. **8380**

**CABEZA BROCA PUNTA INTERCAMBIABLE**

Indexable Drill **Insert**

Tête foret à embout amovible



**MD/ HM**  
Carbure  
Micrograno

**ALTIN**



Tol.  
k7

IT9~IT10

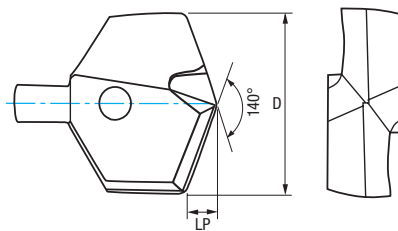

D mm	LP mm	N° Art. P	N° Art. M	N° Art. K	N° Art. N		€
10,00	1,80	56443	56449	56461	56469	1	
10,20	1,90	56472	56475	56478	56479	1	
10,50	1,90	56525	56561	56577	56580	1	
11,00	2,00	56586	56589	56592	56595	1	
11,50	2,10	56598	56601	56607	56613	1	
12,00	2,20	56616	56619	56631	56635	1	
12,50	2,30	56641	56705	56723	56748	1	
13,00	2,40	56273	56279	56282	56285	1	
13,50	2,50	56751	56863	56884	56887	1	
14,00	2,50	56890	56893	56896	56899	1	
14,50	2,60	56905	56975	56977	56980	1	
15,00	2,70	56984	56991	57000	57038	1	
15,50	2,80	57041	57044	57047	57050	1	
16,00	2,90	56295	56298	56301	56307	1	
16,50	3,00	57053	57056	57059	57062	1	
17,00	3,10	57065	57067	57068	57071	1	
17,50	3,20	57074	57077	57080	57083	1	
18,00	3,30	56358	56370	56376	56382	1	
18,50	3,40	57089	57095	57101	57107	1	
19,00	3,50	57113	57119	57143	57159	1	
19,50	3,50	57160	57166	57228	57242	1	
20,00	3,60	54998	55001	55045	55057	1	
20,50	3,70	57248	57254	57260	57266	1	
21,00	3,80	57269	57272	57278	57296	1	
21,50	3,90	57302	57324	57336	57348	1	
22,00	4,00	55060	55063	55074	55078	1	
22,50	4,10	57360	57372	57408	57420	1	
23,00	4,20	57444	57468	57487	57492	1	
23,50	4,30	57493	57498	57499	57502	1	
24,00	4,40	55090	55096	55108	55117	1	
24,50	4,50	57508	57511	57516	57519	1	

D mm	LP mm	N° Art. P	N° Art. M	N° Art. K	N° Art. N		€
25,00	4,50	57522	57528	57540	57543	1	
25,50	4,60	57566	57569	57572	57575	1	
26,00	4,70	55120	55123	55132	55138	1	
26,50	4,80	57576	57578	57582	57588	1	
27,00	4,90	57603	57609	57623	57626	1	
27,50	5,00	57629	57631	57632	57634	1	
28,00	5,10	57635	57637	57639	57641	1	
28,50	5,20	57644	57645	57681	57684	1	
29,00	5,30	57702	57726	57729	57732	1	
29,50	5,40	57735	57742	57745	57748	1	
30,00	5,50	55144	55244	55246	55254	1	
30,50	5,60	57751	57754	57757	57760	1	
31,00	5,60	57763	57766	57769	57772	1	
31,50	5,70	57775	57778	57781	57798	1	
32,00	5,80	57809	57811	57812	57814	1	
32,50	5,90	57815	57817	57818	57820	1	
33,00	6,00	55396	55402	55408	55417	1	
33,50	6,10	57821	57823	57824	57826	1	
34,00	6,20	57921	57933	57936	57945	1	
34,50	6,30	57947	57950	57951	57953	1	
35,00	6,40	57954	57956	57959	57960	1	
35,50	6,50	57962	57963	57965	57966	1	
36,00	6,60	55420	55429	55441	55447	1	
36,50	6,60	57968	57969	57971	57972	1	
37,00	6,70	57974	57977	57983	57989	1	
37,50	6,80	57990	57992	57995	57999	1	
38,00	6,90	58014	58023	58035	58052	1	
38,50	7,00	58055	58056	58061	58064	1	
39,00	7,10	58067	58083	58092	58107	1	
39,50	7,20	58110	58119	58128	58131	1	
39,99	7,30	58143	58156	58159	58165	1	

**P M K** En stock / In stock / En stock

**N** Bajo demanda / Upon request / Sur demande

1. El inserto intercambiable fácil de manipular, facilita el reemplazo del mismo en la propia máquina.
2. La combinación de posicionamiento del tornillo de bloqueo central, la ranura en V y la guía cilíndrica mantiene una fuerza de bloqueo y una fuerza de perforación consistentes, estables y fiables.
3. Los materiales óptimos, el recubrimiento de última generación y la tecnología de rectificado de precisión maximizan su rendimiento.
4. La construcción del inserto de alta resistencia lo hace apto para taladrar con altos avances.
5. Portaherramientas con mango ISO-9766.

1. The easy-to-handle interchangeable insert makes it easy to replace the insert on the machine itself.
2. The positioning combination of central locking screw, V-groove and cylindrical guide maintains consistent, stable and reliable locking force and drilling force.
3. Optimum materials, state-of-the-art coating and precision grinding technology maximise performance.
4. The heavy duty insert construction makes it suitable for high feed drilling.
5. Tool holder with ISO-9766 shank.

1. La plaquette interchangeable, facile à manipuler, permet de la remplacer facilement sur la machine elle-même.
2. La combinaison de positionnement de la vis de blocage centrale, de la rainure en V et du guide cylindrique permet d'obtenir une force de blocage et une force de perçage cohérentes, stables et fiables.
3. Des matériaux optimaux, un revêtement de pointe et une technologie de rectification de précision maximisent les performances.
4. La construction robuste de la plaquette permet de réaliser des trous à avance élevée.
5. Porte-outils avec queue ISO-9766.



Ref. **8381****CUERPO BROCA PUNTA INTERCAMBIABLE REFRIGERACIÓN INTERIOR 3XD**

3XD Internal Cooling Indexable Drill Body

Corps foret à embout amovible lubrification interne 3XD

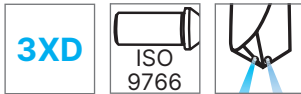
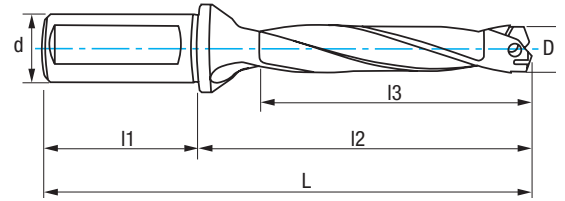

D mm	L mm	l1 mm	l2 mm	l3 mm	d mm		N° Art. HSS	€
10,00-10,49	96	48	48	31,50	16	1	58168	
10,50-10,99	98	48	50	33,00	16	1	58180	
11,00-11,49	100	48	52	34,50	16	1	58195	
11,50-11,99	102	48	54	36,00	16	1	58204	
12,00-12,49	105	48	57	37,50	16	1	58218	
12,50-12,99	107	48	59	39,00	16	1	58228	
13,00-13,49	109	48	61	40,50	16	1	55486	
13,50-13,99	111	48	63	42,00	16	1	58281	
14,00-14,49	113	48	65	43,50	16	1	58357	
14,50-14,99	115	48	67	45,00	16	1	58366	
15,00-15,99	122	50	72	48,00	20	1	58374	
16,00-16,99	127	50	77	51,00	20	1	55509	
17,00-17,99	131	50	81	54,00	20	1	58381	
18,00-18,99	141	56	85	57,00	25	1	55628	
19,00-19,99	146	56	90	60,00	25	1	58388	
20,00-20,99	150	56	94	63,00	25	1	55764	
21,00-21,99	154	56	98	66,00	25	1	58393	
22,00-22,99	158	56	102	69,00	25	1	55895	
23,00-23,99	163	56	107	72,00	25	1	58402	
24,00-24,99	172	60	112	75,00	32	1	55907	
25,00-25,99	176	60	116	78,00	32	1	58410	
26,00-26,99	181	60	121	81,00	32	1	56041	
27,00-27,99	185	60	125	84,00	32	1	58414	
28,00-28,99	189	60	129	87,00	32	1	58429	
29,00-29,99	193	60	133	90,00	32	1	58435	
30,00-30,99	198	60	138	93,00	32	1	56195	
31,00-31,99	202	60	142	96,00	32	1	58444	
32,00-32,99	206	60	146	99,00	32	1	58450	
33,00-33,99	211	60	151	102,00	32	1	56229	
34,00-34,99	226	70	156	105,00	40	1	58459	
35,00-35,99	230	70	160	108,00	40	1	58468	
36,00-36,99	234	70	164	111,00	40	1	56241	
37,00-37,99	239	70	169	114,00	40	1	58477	
38,00-38,99	243	70	173	117,00	40	1	58485	
39,00-39,99	252	70	182	123,00	40	1	58492	

<b>Ref. 8805</b>		<b>Ref. 8801</b>
<b>TP-06 M2×9</b> Art. 70331 - €	1	<b>ZTP-06</b> Art. 70442 €
<b>TP-06 M2×10</b> Art. 70346 - €		
<b>TP-06 M2×11,5</b> Art. 70356 - €		
<b>TP-07 M2,5×13</b> Art. 70359 - €		<b>ZTP-07</b> Art. 70445 €
<b>TP-07 M2,5×15</b> Art. 70362 - €		
<b>TP-09 M3×16</b> Art. 70364 - €		<b>ZTP-09</b> Art. 70448 €
<b>TP-09 M3×17</b> Art. 70370 - €		
<b>TP-09 M3×20</b> Art. 70373 - €		<b>ZTP-10</b> Art. 70454 €
<b>TP-10 M3,5×22</b> Art. 70376 - €		
<b>TP-10 M3,5×24</b> Art. 70382 - €		<b>ZTP-15</b> Art. 70457 €
<b>TP-15 M4×26</b> Art. 70388 - €		
<b>TP-20 M5×29</b> Art. 70397 - €		<b>ZTP-20</b> Art. 70466 €
<b>TP-20 M5×32</b> Art. 70425 - €		
<b>TP-25 M6×35</b> Art. 70434 - €		<b>ZTP-25</b> Art. 70472 €



Ref. **8381**

**CUERPO BROCA PUNTA INTERCAMBIABLE REFRIGERACIÓN INTERIOR 5XD**  
 5XD Internal Cooling Indexable Drill Body  
 Corps foret à embout amovible lubrification interne 5XD

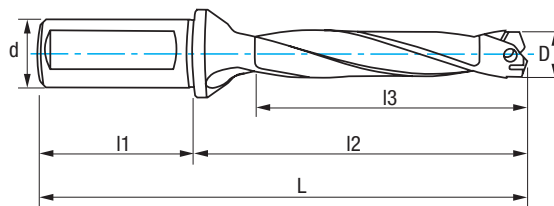

D mm	L mm	l1 mm	l2 mm	l3 mm	d mm		N° Art. HSS	€
10,00-10,49	117	48	69	52,50	16	1	58174	
10,50-10,99	120	48	72	55,00	16	1	58185	
11,00-11,49	123	48	75	57,50	16	1	58197	
11,50-11,99	126	48	78	60,00	16	1	58213	
12,00-12,49	130	48	82	62,50	16	1	58222	
12,50-12,99	133	48	85	65,00	16	1	58267	
13,00-13,49	136	48	88	67,50	16	1	55501	
13,50-13,99	139	48	91	70,00	16	1	58290	
14,00-14,49	142	48	94	72,50	16	1	58360	
14,50-14,99	145	48	97	75,00	16	1	58369	
15,00-15,99	154	50	104	80,00	20	1	58378	
16,00-16,99	161	50	111	85,00	20	1	55576	
17,00-17,99	167	50	117	90,00	20	1	58384	
18,00-18,99	179	56	123	95,00	25	1	55678	
19,00-19,99	186	56	130	100,00	25	1	58390	
20,00-20,99	192	56	136	105,00	25	1	55767	
21,00-21,99	198	56	142	110,00	25	1	58396	
22,00-22,99	204	56	148	115,00	25	1	55898	
23,00-23,99	211	56	155	120,00	25	1	58405	
24,00-24,99	222	60	162	125,00	32	1	55908	
25,00-25,99	228	60	168	130,00	32	1	58411	
26,00-26,99	235	60	175	135,00	32	1	56068	
27,00-27,99	241	60	181	140,00	32	1	58417	
28,00-28,99	247	60	187	145,00	32	1	58431	
29,00-29,99	253	60	193	150,00	32	1	58438	
30,00-30,99	260	60	200	155,00	32	1	56207	
31,00-31,99	266	60	206	160,00	32	1	58446	
32,00-32,99	272	60	212	165,00	32	1	58453	
33,00-33,99	279	60	219	170,00	32	1	56231	
34,00-34,99	296	70	226	175,00	40	1	58462	
35,00-35,99	302	70	232	180,00	40	1	58471	
36,00-36,99	308	70	238	185,00	40	1	56243	
37,00-37,99	315	70	245	190,00	40	1	58480	
38,00-38,99	321	70	251	195,00	40	1	58486	
39,00-39,99	252	70	264	205,00	40	1	58495	

<b>Ref. 8805</b>		<b>Ref. 8801</b>
<b>TP-06 M2×9</b> Art. 70331 - €	1	<b>ZTP-06</b> Art. 70442 €
<b>TP-06 M2×10</b> Art. 70346 - €		
<b>TP-06 M2×11,5</b> Art. 70356 - €		
<b>TP-07 M2,5×13</b> Art. 70359 - €		<b>ZTP-07</b> Art. 70445 €
<b>TP-07 M2,5×15</b> Art. 70362 - €		
<b>TP-09 M3×16</b> Art. 70364 - €		
<b>TP-09 M3×17</b> Art. 70370 - €		<b>ZTP-09</b> Art. 70448 €
<b>TP-09 M3×20</b> Art. 70373 - €		
<b>TP-10 M3,5×22</b> Art. 70376 - €		<b>ZTP-10</b> Art. 70454 €
<b>TP-10 M3,5×24</b> Art. 70382 - €		
<b>TP-15 M4×26</b> Art. 70388 - €		<b>ZTP-15</b> Art. 70457 €
<b>TP-20 M5×29</b> Art. 70397 - €		
<b>TP-20 M5×32</b> Art. 70425 - €		<b>ZTP-20</b> Art. 70466 €
<b>TP-25 M6×35</b> Art. 70434 - €		<b>ZTP-25</b> Art. 70472 €



Ref. **8381**

**CUERPO BROCA PUNTA INTERCAMBIABLE REFRIGERACIÓN INTERIOR 8XD**

8XD Internal Cooling Indexable Drill Body

Corps foret à embout amovible lubrification interne 8XD

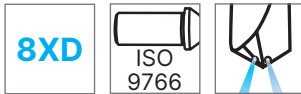
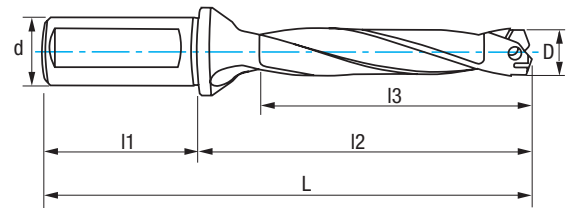

D mm	L mm	l1 mm	l2 mm	l3 mm	d mm	3D Icon	N° Art. HSS	€
10,00-10,49	148	48	100	84,00	16	1	58177	
10,50-10,99	153	48	105	88,00	16	1	58189	
11,00-11,49	158	48	110	92,00	16	1	58203	
11,50-11,99	162	48	114	96,00	16	1	58216	
12,00-12,49	167	48	119	100,00	16	1	58227	
12,50-12,99	172	48	124	104,00	16	1	58272	
13,00-13,49	176	48	128	108,00	16	1	55507	
13,50-13,99	181	48	133	112,00	16	1	58354	
14,00-14,49	186	48	138	116,00	16	1	58363	
14,50-14,99	190	48	142	120,00	16	1	58372	
15,00-15,99	202	50	152	128,00	20	1	58375	
16,00-16,99	212	50	162	136,00	20	1	55600	
17,00-17,99	221	50	171	144,00	20	1	58387	
18,00-18,99	236	56	180	152,00	25	1	55752	
19,00-19,99	246	56	190	160,00	25	1	58392	
20,00-20,99	255	56	199	168,00	25	1	55773	
21,00-21,99	264	56	208	176,00	25	1	58399	
22,00-22,99	273	56	217	184,00	25	1	55901	
23,00-23,99	283	56	227	192,00	25	1	58408	
24,00-24,99	297	60	237	200,00	32	1	56017	
25,00-25,99	306	60	246	208,00	32	1	58413	
26,00-26,99	316	60	256	216,00	32	1	56128	
27,00-27,99	325	60	265	224,00	32	1	58420	
28,00-28,99	334	60	274	232,00	32	1	58432	
29,00-29,99	343	60	283	240,00	32	1	58441	
30,00-30,99	353	60	293	248,00	32	1	56219	
31,00-31,99	362	60	302	256,00	32	1	58447	
32,00-32,99	371	60	311	264,00	32	1	58456	
33,00-33,99	381	60	321	272,00	32	1	56235	
34,00-34,99	401	70	331	280,00	40	1	58465	
35,00-35,99	410	70	340	288,00	40	1	58474	
36,00-36,99	419	70	349	296,00	40	1	56255	
37,00-37,99	429	70	359	304,00	40	1	58483	
38,00-38,99	438	70	368	312,00	40	1	58489	
39,00-39,99	457	70	387	328,00	40	1	58498	

Ref. 8805	Ref. 8801
<b>TP-06 M2×9</b> Art. 70331 - €	<b>ZTP-06</b> Art. 70442 €
<b>TP-06 M2×10</b> Art. 70346 - €	
<b>TP-06 M2×11,5</b> Art. 70356 - €	
<b>TP-07 M2,5×13</b> Art. 70359 - €	<b>ZTP-07</b> Art. 70445 €
<b>TP-07 M2,5×15</b> Art. 70362 - €	
<b>TP-09 M3×16</b> Art. 70364 - €	<b>ZTP-09</b> Art. 70448 €
<b>TP-09 M3×17</b> Art. 70370 - €	
<b>TP-09 M3×20</b> Art. 70373 - €	<b>ZTP-10</b> Art. 70454 €
<b>TP-10 M3,5×22</b> Art. 70376 - €	
<b>TP-10 M3,5×24</b> Art. 70382 - €	<b>ZTP-15</b> Art. 70457 €
<b>TP-15 M4×26</b> Art. 70388 - €	
<b>TP-20 M5×29</b> Art. 70397 - €	<b>ZTP-20</b> Art. 70466 €
<b>TP-20 M5×32</b> Art. 70425 - €	
<b>TP-25 M6×35</b> Art. 70434 - €	<b>ZTP-25</b> Art. 70472 €



Ref. **8536**

**PLAQUITA INTERCAMBIABLE TORNEADO RCGT**  
RCGT Turning Indexable Insert  
Plaquette tournage RCGT

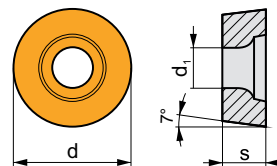

ISO	Dimensiones Dimensions			Condiciones Corte Cutting Conditions Conditions coupe			N° Art. P-010	€
	d mm	s mm	d <sub>1</sub> mm	f mm	a <sub>p</sub> mm			
<b>Acabado / Finishing / Finition</b>								
RCGT-0803M0-F-ZAL	8,00	3,18	3,40	0,05-0,25	0,50-2,50	10	70773	
RCGT-1003M0-F-ZAL	10,00	3,18	4,40	0,10-0,30	1,00-3,00	10	48761	
RCGT-1204M0-F-ZAL	12,00	4,76	4,40	0,10-0,35	1,00-3,50	10	45170	



Ejemplo Pedido / Order Example / Exemple commande:  
Ref. 8536 RCGT-0803M0-F-ZAL P-010

Porta Plaquetas / Tool Holder / Porte-Plaquettes:  
Ref. 8705

Ref. **8537**

**PLAQUITA INTERCAMBIABLE TORNEADO RCMT**  
RCMT Turning Indexable Insert  
Plaquette tournage RCMT

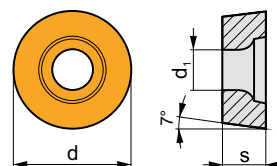

ISO	Dimensiones Dimensions			Condiciones Corte Cutting Conditions Conditions coupe			N° Art. C-G15	N° Art. C-G25	N° Art. P-H10	€
	d mm	s mm	d <sub>1</sub> mm	f mm	a <sub>p</sub> mm					
<b>Semi-Desbaste / Semi-Roughing / Semi-Ébauche</b>										
RCMT-0803M0-E-ZRR	8,00	3,18	3,40	0,10-0,80	0,80-3,20	10	70749	77229		
RCMT-1003M0-E-ZRR	10,00	3,18	4,40	0,12-1,00	1,00-4,00	10	70752	13773		
RCMT-10T3M0-E-ZRR	10,00	3,97	4,40	0,16-1,40	1,00-4,00	10	80783	80786		
RCMT-1204M0-E-ZRR	12,00	4,76	4,40	0,20-1,80	1,20-4,80	10	70755	44214		
RCMT-1606M0-E-ZRR	16,00	6,35	5,50	0,25-2,30	1,60-6,40	10	70758	69051		
<b>INOX Semi-Acabado / Semi-Finishing Stainless / Inox Semi-Finition</b>										
RCMT-0803M0-E-ZMM	8,00	3,18	3,40	0,15-0,40	0,50-3,00	10			24544	
RCMT-1003M0-E-ZMM	10,00	3,18	4,40	0,15-0,45	0,75-4,00	10			53622	



Ejemplo Pedido / Order Example / Exemple commande:  
Ref. 8537 RCMT-0803M0-E-ZRR C-G15

Porta Plaquetas / Tool Holder / Porte-Plaquettes:  
Ref. 8705





Ref. 8792

PORTA-PLAQUITAS TORNEADO EXTERIOR PLAQUITAS NEGATIVAS DDJN.-93°  
 DDJN.-93° Negative Inserts External Turning Tool-Holder  
 Porte-plaquettes tournage exterior plaquettes negatives DDJN.-93°

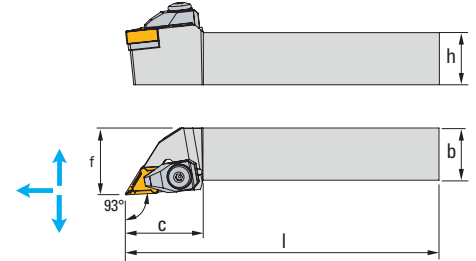

ISO	R Dcha.	N° Art.	L Izda.	N° Art.		h mm	b mm	l mm	c mm	f mm	€						
												Ref. 8815	Ref.8812	Ref.8816	Ref. 8816	Ref. 8812	Ref. 8812
DDJNR-2020K11	●	31140			DN... 1104	20	20	125	30	25							
DDJNL-2020K11			●	31191		20	20	125	30	25		Art. 31237	Art. 31239	Art. 31241	Art. 31243	Art. 31245	Art. 31247
DDJNR-2525M11	●	31200				25	25	150	30	32		€	€	€	€	€	€
DDJNL-2525M11			●	31233		25	25	150	30	32							
DDJNR-2020K15	●	31234			DN... 1504	20	20	125	38	25							
DDJNL-2020K15			●	31235		20	20	125	38	25							
DDJNR-2525M15	●	31236				25	25	150	38	38							
DDJNL-2525M15			●	31019		25	25	150	38	38		Art. 31238	Art. 31240	Art. 31242	Art. 31244	Art. 31246	Art. 31248
DDJNR-2020K15-N	●	31249			DN... 1506	20	20	125	35	25		€	€	€	€	€	€
DDJNL-2020K15-N			●	31250		20	20	125	35	25							
DDJNR-2525M15-N	●	31251				25	25	150	35	32							
DDJNL-2525M15-N			●	31261		25	25	150	35	32							

Plaquita / Insert / Plaqueette:

Ref. 8530

	Placa Base - Base Plate - Plaque de base
	Brida - Clamp - Bride
	Tornillo - Screw - Vis
	Tornillo - Screw - Vis
	Muelle - Spring - Resorte
	Arandela - Washer - Machine à laver

# Ref. 8711

## PORTA-PLAQUITAS TORNEADO EXTERIOR PLAQUITAS NEGATIVAS PWLN.-95° PWLN.-95° Negative Inserts External Turning Tool-Holder Porte-plaquettes tournage exterior plaquettes negatives PWLN.-95°

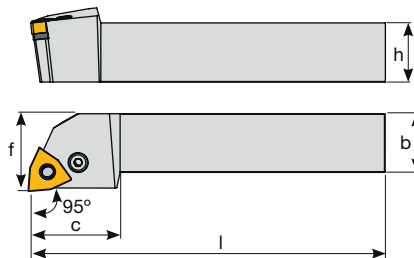

ISO	R Dcha.	N° Art.	L Izda.	N° Art.		h mm	b mm	l mm	c mm	f mm	€			
												Ref. 8815	Ref. 8813	Ref. 8816
PWLN-1616H06	●	72344			WNMG-0604..	16	16	100	25	20		PWLN-06 Art. 59086 €	3,5x12,2 Art. 25953 €	M6x1-17 Art. 25955 €
PWLN-1616H06			●	25720		16	16	100	25	20				
PWLN-2020K06	●	25723				20	20	125	25	25				
PWLN-2020K06			●	25724		20	20	125	25	25				
PWLN-2525M06	●	25736			80529	25	25	150	25	32		PWLN-08 Art. 25952 €	4,5x13 Art. 25954 €	M8x1-21 Art. 25956 €
PWLN-2525M06			●	80529		25	25	150	25	32				
PWLN-2525M08	●	74976			WNMG-0804..	25	25	150	34	32		PWLN-08 Art. 25952 €	4,5x13 Art. 25954 €	M8x1-21 Art. 25956 €
PWLN-2525M08			●	25741		25	25	150	34	32				
PWLN-3232P08	●	25748				32	32	170	34	40				
PWLN-3232P08			●	25759	32	32	170	34	40					

Plaquita / Insert / Plaquette: Ref. 8580

	Placa Base - Base Plate - Plaque de base
	Palanca - Lever - Levier
	Tornillo - Screw - Vis

# Ref. 8705

## PORTA-PLAQUITAS TORNEADO EXTERIOR PLAQUITAS POSITIVAS SRDCN SRDCN Positive Inserts External Turning Tool-Holder Porte-plaquettes tournage exterior plaquettes positives SRDCN

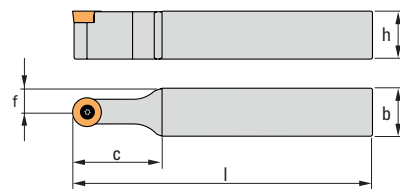

ISO	N° Art.		h mm	b mm	l mm	c mm	f mm	€		
									Ref. 8816	Ref. 8801
SRDCN-2020K08	70728	RC..0803	20	20	125	37	10,00		M3x7 Art. 70192 €	ZT-8 Art. 10506 €
SRDCN-2525M08	70731		25	25	150	37	12,50			
SRDCN-2020K10	24355	RC..1003 / RC..10T3	20	20	125	35	10,00		M3,5x8,5 Art. 70740 €	ZT-15 Art. 10512 €
SRDCN-2525M10	67610		25	25	150	35	12,50			
SRDCN-2020K12	34448	RC..1204	20	20	125	38	10,00		M5x12 Art. 70746 €	ZT-20 Art. 13845 €
SRDCN-2525M12	70733		25	25	150	38	12,50			
SRDCN-2525M16	70735	RC..1606	25	25	150	35	12,50			



	Tornillo - Screw - Vis
	Destornillador Screwdriver Tournevis

Ejemplo Pedido / Order Example / Exemple commande:  
Ref. 8705 SRDCN-2020K08

Plaquita / Insert / Plaquette:  
Refs. 8536-8537

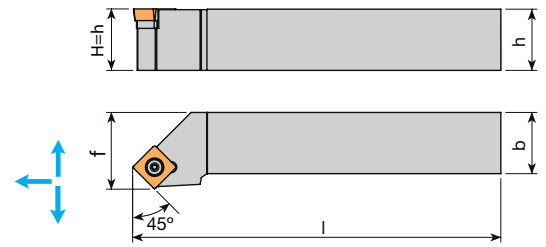

Ref. **8723**
**PORTA-PLAQUITAS TORNEADO EXTERIOR PLAQUITAS POSITIVAS SSSC.-45°**  
 SSSC.-45° Positive Inserts External Turning Tool-Holder  
 Porte-plaquettes tournage exterior plaquettes positives SSSC.-45°

ISO	R Dcha.	N° Art.	L Izda.	N° Art.		h mm	b mm	l mm	f mm	€				
											Ref. 8815	Ref. 8816	Ref. 8816	Ref. 8801
SSSCR-1212F09	●	28386			SC..09T3	12	12	80	16		-	-	T-15-M3,5×11 Art. 31558 €	5 ZT-15 Art. 10512 €
SSSCL-1212F09			●	67800		12	12	80	16		-	-		
SSSCR-1616H09	●	69642				16	16	100	20		SSSC-09 Art. 31553 €	5 M3,5×0,6x M5×0,5×11,3x 3,5xø6 Art. 31556 €	5 T-15-3,5×14 Art. 31560 €	
SSSCL-1616H09			●	28392		16	16	100	20					
SSSCR-2020K12	●	68959			SC..1204	20	20	125	25		5	5	5	5
SSSCL-2020K12			●	28393		20	20	125	25		SSSC-12 Art. 16147 €	M4,5×0,75x M6×0,75×13x 4,5×7,5 Art. 31557 €	T-20-M4,5×16 Art. 31559 €	ZT-20 Art. 13845 €
SSSCR-2525M12	●	39344				25	25	150	32					
SSSCL-2525M12			●	28394		25	25	150	32					

Placa Base - Base Plate - Plaque de base

Tornillo - Screw - Vis

**Plaquita / Insert / Plaque: Ref. 8540**

Tornillo - Screw - Vis

Destornillador - Screwdriver - Tournevis

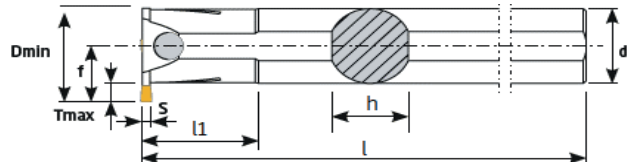
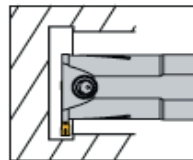
Ref. **8866**
**PORTA-PLAQUITAS DE RANURADO INTERIOR S-GMGG**  
 S-GMGG Internal Grooving Tool-Holder  
 Porte-plaquettes rainurage intérieur S-GMGG

ISO	R Dcha.	N° Art.		d mm	h mm	f mm	l mm	l1 mm	Dmin mm	Tmax mm	s mm	€	
													Ref. 8816
S16Q-GMGR02	●	25493	MGMN-2.00....	16	15	12,50	180	35	21	5,00	2		M5×12 Art. 25531 €
S20Q-GMGR03	●	25494	MGMN-3.00....	20	18	15,50	180	35	26	6,00	3		
S25R-GMGR03	●	25504		25	23	19,00	200	40	32	6,70	3		M5×16 Art. 19194 €
S25R-GMGR04	●	25506	MGMN-4.00....	25	23	18,20	200	40	31	6,00	4		
S32S-GMGR04	●	25507		32	30	21,50	250	60	38	6,00	4		M6×20 Art. 19216 €

\* Portaplaquetas a izquierdas bajo demanda

\* Left-Hand Tool-Holder upon request

\* Porte-plaquettes à gauche sur demande

**Plaquita / Insert / Plaque: Ref. 8601**





Tornillo - Screw - Vis



Ref. **8231**

PORTA-PLAQUITAS FRESADO ALTO AVANCE SLO-03 REFRIGERACIÓN INTERIOR  
Internal Cooling SLO-03 High Feed Tool-Holder  
Porte-Plaquettes fraissage haute avance SLO-03 lubrification interne







ISO	∅ D	∅ dH7	Z	L	N° Art.	€		
							<b>Ref. 8804</b>	<b>Ref. 8801</b>
<b>40E6R40-SLO03</b>	40	16	6	40	48491		<b>M3x7</b> Art. 70192 €	<b>ZT-8</b> Art. 10506 €
<b>50E7R50-SLO03</b>	50	22	7	50	48500		 5	 1
<b>63E9R50-SLO03</b>	63	22	9	50	70191			



Ref. **8261**

PORTA-PLAQUITAS FRESADO ALTO AVANCE SLO-03 REFRIGERACIÓN INTERIOR  
Internal Cooling SLO-03 High Feed Tool-Holder  
Porte-Plaquettes Fraissage haute avance SLO-03 lubrification interne



ISO	D	dH6	L	I2	Z	N° Art.	€		
								<b>Ref. 8804</b>	<b>Ref. 8801</b>
<b>20-SLO-03</b>	20	20	150	60	3	44837		<b>M3x7</b> Art. 70192 €	<b>ZT-8</b> Art. 10506 €
<b>25-SLO-03</b>	25	25	150	60	4	44930		 5	 1



Ref. **8691**

PLACA INTERCAMBIABLE FRESADO LOGX  
LOGX Milling Indexable Insert  
Plaquette Fraissage LOGX



ISO	Dimensiones Dimensions				Condiciones Corte Cutting Conditions Conditions coupe				N° Art. P-630	N° Art. P-640	€
	l mm	d mm	s mm	d <sub>1</sub> mm	f mm	a <sub>p</sub> mm					
<b>Semi-Acabado / Semi-Finishing / Semi-Finition</b>											
<b>LOGX-030310-ZSG</b>	11,90	6,20	3,96	3,45	0,30-1,60	0,30-0,90	10	44834	70190		



Ejemplo Pedido / Order Example / Exemple commande:  
Ref. 8691 LOGX-030310-ZSG P-630

Porta Plaquetas / Tool Holder / Porte-Plaquettes:  
**Refs. 8261-8231**









Ref. **8233**

**PORTA-PLAQUITAS FRESADO ALTO AVANCE SWN-09 REFRIGERACIÓN INTERIOR**  
**Internal Cooling SWN-09 High Feed Tool-Holder**  
**Porte-Plaquettes Fraisage haute avance SWN-09 lubrification interne**



ISO	D	dH7	L	Z	N° Art.	€		
<b>040E4R40-SWN09</b>	40	16	40	4	48647		<b>Ref. 8816</b>	<b>Ref. 8801</b>
<b>050E5R40-SWN09</b>	50	22	40	5	48650		<b>M3x7</b> Art. 70192 €	 5 <b>ZT-8</b> Art. 10506 €
<b>063E6R40-SWN09</b>	63	22	40	6	74821			 1

Ref. **8692**

**PLACA INTERCAMBIABLE FRESADO WNMX**  
**WNMX Milling Indexable Insert**  
**Plaquette Fraisage WNMX**



ISO	Dimensiones Dimensions				Condiciones Corte Cutting Conditions Conditions coupe				N° Art. <b>P-630</b>	N° Art. <b>P-640</b>	€
	d mm	s mm	r mm	d <sub>1</sub> mm	f mm	a <sub>p</sub> mm					
<b>WNMX-09T316-ZMG</b>	9,53	3,97	1,60	3,60	0,40-1,50	0,40-1,35	10	48662	74819		





- Con las plaquetas de fresado de doble cara WNMX obtenemos 6 filos de corte.
- Plaqueta económica de alto avance multifuncional.
- Profundidad máxima de corte de 1,35 mm.
- With double-sided WNMX milling inserts, we obtain 6 cutting edges.
- An economical, high-feed multi-functional insert.
- Maximum cutting depth of 1.35 mm.
- Avec les plaquettes de fraisage double face WNMX, nous obtenons 6 arêtes de coupe.
- Une plaquette économique à avance élevée multifonctionnelle.
- Profondeur de coupe maximale de 1,35 mm.

Ref. **8234**

PORTA-PLAQUITAS FRESADO **ALTO AVANCE SSD-12 REFRIGERACIÓN INTERIOR**  
 Internal Cooling SSD-12 High Feed Tool-Holder  
 Porte-Plaquettes Fraisage **haute avance SSD-12 lubrification interne**





ISO	D	dh7	L	Z	N° Art.	€		
50E4R40-SSD12	50	22	40	4	77740		Ref. 8804	Ref. 8801
63E5R40-SSD12	63	22	40	5	77749		M4x8 Art. 77794 €	ZT-15 Art. 10512 €



Ref. **8262**

PORTA-PLAQUITAS FRESADO **ALTO AVANCE SSD-12 REFRIGERACIÓN INTERIOR**  
 Internal Cooling SSD-12 High Feed Tool-Holder  
 Porte-Plaquettes Fraisage **haute avance SSD-12 lubrification interne**



ISO	D	dh6	L	I2	Z	N° Art.	€		
32-SSD-12	32	32	160	70	2	77795		Ref. 8804	Ref. 8801
40-SSD-12	40	32	200	70	3	77796		M4x8 Art. 77794 €	ZT-15 Art. 10512 €



Ref. **8693**

PLACA INTERCAMBIABLE FRESADO SDMT  
 SDMT Milling Indexable Insert  
 Plaquette Fraisage SDMT







ISO	Dimensiones Dimensions				Condiciones Corte Cutting Conditions Conditions coupe				N° Art. P-620	N° Art. P-630	€
	l mm	r mm	s mm	d <sub>1</sub> mm	f mm	a <sub>p</sub> mm					
SDMT-1205ZDTN-ZMG	12,7	15	5,56	4,6	0,5-1,8	0,3-1,5	10	54992	48659		



- **Plaquita económica con 4 robustos filos de corte y de alto avance para una amplia variedad de materiales y aplicaciones.**
- **Profundidad máxima de corte de 1,5 mm**
- **Economical insert with 4 strong cutting edges and high feed for a wide variety of materials and applications**
- **Maximum cutting depth of 1.5 mm**
- **Plaquette économique avec 4 arêtes de coupe robustes et avance élevée pour une large gamme de matériaux et d'applications**
- **Profondeur de coupe maximale de 1,5 mm**



Ref. **8236**
**PORTA-PLAQUITAS FRESADO S45SN12 REFRIGERACIÓN INTERIOR**  
 Internal Cooling S45SN12 Tool-Holder  
 Porte-Plaquettes Fraisage S45SN12 **lubrification interne**

ISO	D	dH7	L	Z	N° Art.	€					
							Ref. 8816		Ref. 8801		
<b>050E5R40-S45SN12</b>	50	22	40	5	70916						
<b>063E6R40-S45SN12</b>	63	22	40	6	48653			 5		 1	
<b>080E7R50-S45SN12</b>	80	27	50	7	70949		M5×12 Art. 70746 €		ZT-20 Art. 13845 €		
<b>100E8R50-S45SN12</b>	100	32	50	8	70955						
<b>125E10R63-S45SN12</b>	125	40	63	10	70986						

Ref. **8673**
**PLACA INTERCAMBIABLE FRESADO SNMX**  
 SNMX Milling Indexable Insert  
 Plaquette Fraisage SNMX

ISO	Dimensiones Dimensions					Condiciones Corte Cutting Conditions Conditions coupe				N° Art. P-630	N° Art. P-640	€
	l mm	d mm	s mm	b mm	d <sub>1</sub> mm	f mm	a <sub>p</sub> mm					
<b>SNMX-1205-ZMG</b>	12,7	12,7	6,4	1,5	6	0,08-0,3	0,3-6	10	48665	70785		
<b>SNMX-1205-ZRG</b>	12,7	12,7	6,4	1,5	6	0,08-0,3	0,3-6	10	70788	70829		



# Ref. 8296

**PORTA-PLAQUITAS DE ACHAFLANADO CHS.. A 45°**  
 45° CHS.. Chamfering Tool-Holder  
 Porte-Plaquettes chanfreinage CHS.. 45°



ISO	D	d	L	I	Z	N° Art.	€		
25M-32CHSP09	32	25	150	30	2	26647		Ref. 8816	Ref. 8801
25M-40CHSP09	40	25	150	50	3	77477		M3,5X8,5 Art. 70740 €	ZT-15 Art. 10512 €



# Ref. 8665

**PLACA INTERCAMBIABLE FRESADO SPMG**  
 SPMG Milling Indexable Insert  
 Plaquette Fraisage SPMG



ISO	Dimensiones Dimensions				Condiciones Corte Cutting Conditions Conditions coupe				N° Art. P-630	N° Art. P-640	€
	l mm	s mm	d <sub>1</sub> mm	r mm	f mm	a <sub>p</sub> mm					
SPMG-090408-ZMG	9,8	4,3	4,05	0,8	0,10-0,15	2,5	10	26654			
SPMG-090408-ZRG	9,8	4,3	4,05	0,8	0,10-0,15	2,5	10		77476		



# Ref. 8297

**PORTA-PLAQUITAS ACHAFLANADO AJUSTABLE CHS** **REFRIGERACIÓN INTERIOR**  
**Internal Cooling** CHS Adjustable Angle Chamfering Tool-Holder  
 Porte-plaquettes chanfreinage angle réglable CHS **lubrification interne**



ISO	Dmax	Dmin	d	L	γ°	N° Art.	€				
CHS25H-05-31-TC16	31	5	25	100	10-80	77499		Ref. 8811	Ref. 8816	Ref. 8816	Ref. 8801
								Z-H21 Art. 77503 €	M6X15 Art. 77504 €	M3,5X8,5 Art. 70740 €	ZT-15 Art. 10512 €





# PINZAS DE SUJECIÓN ER PARA PORTAHERRAMIENTAS

## ER Collets for Tool-Holders

### Pinces ER pour les porte-outils



Ref. 8390

**ULTRAPRECISIÓN**

**P**  
↗ 0,005

Ref. 8391

**ALTA PRECISIÓN**

**A**  
↗ 0,01

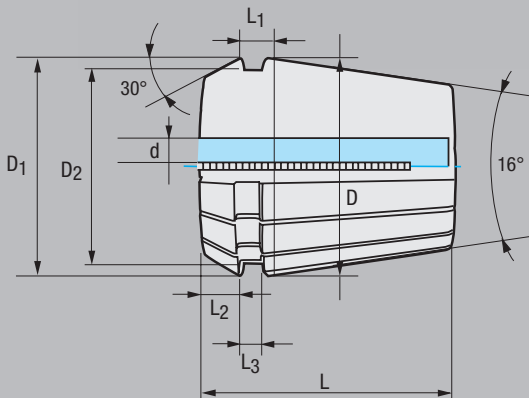

TIPO Type Type	d	D	D1	D2	L	L1	L2	L3	Compresión elástica Elastic compression Compression élastique
ER11	1,0-7,0	11,50	11,50	9,50	18,00	3,80	2,50	2,00	0,50
ER16	1,0-2,5	16,00	17,00	13,80	27,50	6,26	4,00	2,70	0,50
	>2,5-10,0	16,00	17,00	13,80	27,50	6,26	4,00	2,70	1,00
ER20	2,0-2,5	20,00	21,00	17,40	31,50	6,36	4,80	2,80	0,50
	>2,5-13,0	20,00	21,00	17,40	31,50	6,36	4,80	2,80	1,00
ER25	2,0-2,5	25,00	26,00	22,00	34,00	6,66	5,00	3,10	0,50
	>2,5-16,0	25,00	26,00	22,00	34,00	6,66	5,00	3,10	1,00
ER32	>3,0-20,0	32,00	33,00	29,20	40,00	7,16	5,50	3,60	1,00
ER40	3,0-26,0	40,00	41,00	36,20	46,00	7,66	7,00	4,10	1,00

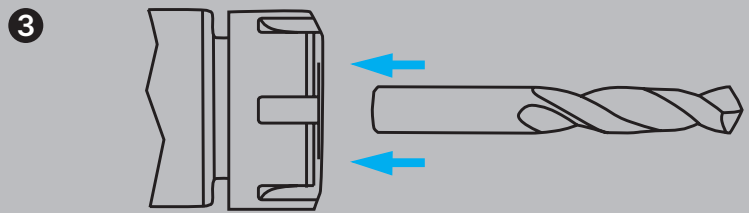
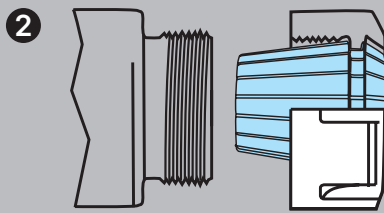
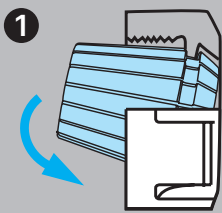

#### COLOCACIÓN DE LA HERRAMIENTA

- Colocar la pinza ER en la tuerca ER
- Bloquear la pinza ER y la tuerca ER en el porta
- Insertar la herramienta en la pinza ER y luego apretar la tuerca

#### TOOL INSTALLATION

- Put the ER collet into the ER nut
- Lock the ER collet and the ER nut into the holder
- Insert the tool into the ER collet and then tighten the nut

#### MISE EN PLACE DE L'OUTIL

- Mettez la pince ER dans l'écrou ER
- Verrouillez la pince ER et l'écrou ER dans le porte-outil
- Insérez l'outil dans la pince ER puis serrez l'écrou

Ref. **8390**

**PINZAS DE SUJECIÓN ER DE ULTRAPRECISIÓN**

Ultra Precision ER Collets

Pinces de fixation ER ultraprécision



Clase Class Classe <b>P</b>	Tol. <b>0,005</b> mm	DIN 6499 B
--------------------------------------	----------------------------	---------------

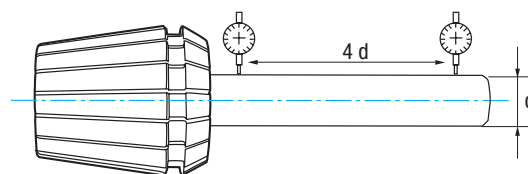

TIPO Type Type	RANGO Range Intervalle	Nº Art.	€
----------------------	------------------------------	------------	---

**ER11**

ER11-1	1,0-0,5	22134	
ER11-1.5	1,5-1,0	22135	
ER11-2	2,0-1,5	22136	
ER11-2.5	2,5-2,0	22137	
ER11-3	3,0-2,5	22138	
ER11-3.5	3,5-3,0	22139	
ER11-4	4,0-3,5	22141	
ER11-4.5	4,5-4,0	22147	
ER11-5	5,0-4,5	22148	
ER11-5.5	5,5-5,0	22149	
ER11-6	6,0-5,5	22152	
ER11-6.5	6,5-6,0	22153	
ER11-7	7,0-6,5	22157	

**ER16**

ER16-1	1,0-0,5	22158	
ER16-2	2,0-1,5	22159	
ER16-3	3,0-2,0	22160	
ER16-4	4,0-3,0	22161	
ER16-5	5,0-4,0	22163	
ER16-6	6,0-5,0	22164	
ER16-7	7,0-6,0	22165	
ER16-8	8,0-7,0	22166	
ER16-9	9,0-8,0	22167	
ER16-10	10,0-9,0	22168	

**ER20**

ER20-2	2,0-1,5	22169	
ER20-3	3,0-2,0	22170	
ER20-4	4,0-3,0	22171	
ER20-5	5,0-4,0	22172	
ER20-6	6,0-5,0	22173	
ER20-7	7,0-6,0	22174	
ER20-8	8,0-7,0	22175	
ER20-9	9,0-8,0	22176	
ER20-10	10,0-9,0	22177	
ER20-11	11,0-10,0	22178	
ER20-12	12,0-11,0	22179	
ER20-13	13,0-12,0	22180	

TIPO Type Type	RANGO Range Intervalle	Nº Art.	€
----------------------	------------------------------	------------	---

**ER25**

ER25-2	2,0-1,5	22185	
ER25-3	3,0-2,0	22186	
ER25-4	4,0-3,0	22187	
ER25-5	5,0-4,0	22188	
ER25-6	6,0-5,0	22189	
ER25-7	7,0-6,0	22190	
ER25-8	8,0-7,0	22195	
ER25-9	9,0-8,0	22196	
ER25-10	10,0-9,0	22197	
ER25-11	11,0-10,0	22198	
ER25-12	12,0-11,0	22200	
ER25-13	13,0-12,0	22201	
ER25-14	14,0-13,0	22202	
ER25-15	15,0-14,0	22203	
ER25-16	16,0-15,0	22204	

**ER32**

ER32-3	3,0-2,0	22206	
ER32-4	4,0-3,0	22208	
ER32-5	5,0-4,0	22209	
ER32-6	6,0-5,0	22210	
ER32-7	7,0-6,0	22219	
ER32-8	8,0-7,0	22225	
ER32-9	9,0-8,0	22230	
ER32-10	10,0-9,0	22231	
ER32-11	11,0-10,0	22253	
ER32-12	12,0-11,0	22259	
ER32-13	13,0-12,0	22276	
ER32-14	14,0-13,0	22277	
ER32-15	15,0-14,0	22279	
ER32-16	16,0-15,0	22282	
ER32-17	17,0-16,0	22285	
ER32-18	18,0-17,0	22286	
ER32-19	19,0-18,0	22287	
ER32-20	20,0-19,0	22290	

TIPO Type Type	RANGO Range Intervalle	Nº Art.	€
----------------------	------------------------------	------------	---

**ER40**

ER40-3	3,0-2,0	22291	
ER40-4	4,0-3,0	22292	
ER40-5	5,0-4,0	22295	
ER40-6	6,0-5,0	22305	
ER40-7	7,0-6,0	22310	
ER40-8	8,0-7,0	22313	
ER40-9	9,0-8,0	22314	
ER40-10	10,0-9,0	22316	
ER40-11	11,0-10,0	22318	
ER40-12	12,0-11,0	22319	
ER40-13	13,0-12,0	22333	
ER40-14	14,0-13,0	22335	
ER40-15	15,0-14,0	22338	
ER40-16	16,0-15,0	22339	
ER40-17	17,0-16,0	22345	
ER40-18	18,0-17,0	22355	
ER40-19	19,0-18,0	22356	
ER40-20	20,0-19,0	22357	
ER40-21	21,0-20,0	22358	
ER40-22	22,0-21,0	22359	
ER40-23	23,0-22,0	22360	
ER40-24	24,0-23,0	22361	
ER40-25	25,0-24,0	22362	
ER40-26	26,0-25,0	23033	



Ref. **8391**

**PINZAS DE SUJECIÓN ER DE ALTA PRECISIÓN**

High Precision ER Collets

Pinces de fixation ER haute précision



Clase Class Classe <b>A</b>	Tol. <b>0,01</b> mm	DIN 6499 B
--------------------------------------	---------------------------	---------------

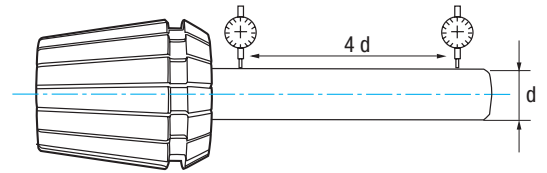

TIPO Type Type	RANGO Range Intervalle	N° Art.	€
----------------------	------------------------------	------------	---

ER11			
ER11-1	1,0-0,5	22363	
ER11-1.5	1,5-1,0	22364	
ER11-2	2,0-1,5	22366	
ER11-2.5	2,5-2,0	22367	
ER11-3	3,0-2,5	22368	
ER11-3.5	3,5-3,0	22369	
ER11-4	4,0-3,5	22375	
ER11-4.5	4,5-4,0	22376	
ER11-5	5,0-4,5	22377	
ER11-5.5	5,5-5,0	22378	
ER11-6	6,0-5,5	22379	
ER11-6.5	6,5-6,0	22380	
ER11-7	7,0-6,5	22381	

ER16			
ER16-1	1,0-0,5	22382	
ER16-2	2,0-1,5	22383	
ER16-3	3,0-2,0	22384	
ER16-4	4,0-3,0	22385	
ER16-5	5,0-4,0	22386	
ER16-6	6,0-5,0	22387	
ER16-7	7,0-6,0	22388	
ER16-8	8,0-7,0	22390	
ER16-9	9,0-8,0	22393	
ER16-10	10,0-9,0	22394	

ER20			
ER20-2	2,0-1,5	22396	
ER20-3	3,0-2,0	22397	
ER20-4	4,0-3,0	22398	
ER20-5	5,0-4,0	22399	
ER20-6	6,0-5,0	22401	
ER20-7	7,0-6,0	22402	
ER20-8	8,0-7,0	22403	
ER20-9	9,0-8,0	22404	
ER20-10	10,0-9,0	22409	
ER20-11	11,0-10,0	22411	
ER20-12	12,0-11,0	22412	
ER20-13	13,0-12,0	22414	

TIPO Type Type	RANGO Range Intervalle	N° Art.	€
----------------------	------------------------------	------------	---

ER25			
ER25-2	2,0-1,5	22415	
ER25-3	3,0-2,0	22416	
ER25-4	4,0-3,0	22422	
ER25-5	5,0-4,0	22424	
ER25-6	6,0-5,0	22426	
ER25-7	7,0-6,0	22427	
ER25-8	8,0-7,0	22428	
ER25-9	9,0-8,0	22433	
ER25-10	10,0-9,0	22434	
ER25-11	11,0-10,0	22435	
ER25-12	12,0-11,0	22437	
ER25-13	13,0-12,0	22439	
ER25-14	14,0-13,0	22440	
ER25-15	15,0-14,0	22442	
ER25-16	16,0-15,0	22443	

ER32			
ER32-3	3,0-2,0	22444	
ER32-4	4,0-3,0	22445	
ER32-5	5,0-4,0	22446	
ER32-6	6,0-5,0	22447	
ER32-7	7,0-6,0	22452	
ER32-8	8,0-7,0	22453	
ER32-9	9,0-8,0	22454	
ER32-10	10,0-9,0	22455	
ER32-11	11,0-10,0	22458	
ER32-12	12,0-11,0	22461	
ER32-13	13,0-12,0	22462	
ER32-14	14,0-13,0	22467	
ER32-15	15,0-14,0	22468	
ER32-16	16,0-15,0	22469	
ER32-17	17,0-16,0	22471	
ER32-18	18,0-17,0	22476	
ER32-19	19,0-18,0	22478	
ER32-20	20,0-19,0	22479	

TIPO Type Type	RANGO Range Intervalle	N° Art.	€
----------------------	------------------------------	------------	---

ER40			
ER40-3	3,0-2,0	22481	
ER40-4	4,0-3,0	22482	
ER40-5	5,0-4,0	22483	
ER40-6	6,0-5,0	22484	
ER40-7	7,0-6,0	22487	
ER40-8	8,0-7,0	22488	
ER40-9	9,0-8,0	22491	
ER40-10	10,0-9,0	22498	
ER40-11	11,0-10,0	22501	
ER40-12	12,0-11,0	22504	
ER40-13	13,0-12,0	22505	
ER40-14	14,0-13,0	22529	
ER40-15	15,0-14,0	22535	
ER40-16	16,0-15,0	22538	
ER40-17	17,0-16,0	22541	
ER40-18	18,0-17,0	22544	
ER40-19	19,0-18,0	22561	
ER40-20	20,0-19,0	22566	
ER40-21	21,0-20,0	22567	
ER40-22	22,0-21,0	22569	
ER40-23	23,0-22,0	22572	
ER40-24	24,0-23,0	22573	
ER40-25	25,0-24,0	22575	
ER40-26	26,0-25,0	22584	



Set	Pcs	Cont.	N° Art.	Set Price!
ER11	13	1 - 1,5 - 2 - 2,5 - 3 - 3,5 - 4 - 4,5 - 5 - 5,5 - 6 - 6,5 - 7	24563	
ER16	10	1 - 2 - 3 - 4 - 5 - 6 - 7 - 8 - 9 - 10	24571	
ER20	12	2 - 3 - 4 - 5 - 6 - 7 - 8 - 9 - 10 - 11 - 12 - 13	24575	
ER25	15	2 - 3 - 4 - 5 - 6 - 7 - 8 - 9 - 10 - 11 - 12 - 13 - 14 - 15 - 16	24579	

Set	Pcs	Cont.	N° Art.	Set Price!
ER32	18	3 - 4 - 5 - 6 - 7 - 8 - 9 - 10 - 11 - 12 - 13 - 14 - 15 - 16 - 17 - 18 - 19 - 20	24584	
ER40	24	3 - 4 - 5 - 6 - 7 - 8 - 9 - 10 - 11 - 12 - 13 - 14 - 15 - 16 - 17 - 18 - 19 - 20 - 21 - 22 - 23 - 24 - 25 - 26	24590	



Ref. **8392**

**PINZAS DE SUJECIÓN ESTANCAS ERC DE ALTA PRECISIÓN**

High Precision ERC Sealing Collets

Pinces de fixation ERC haute précision



Clase  
Class Classe  
**A**

Tol.  
**0,01**  
mm

DIN  
6499 B

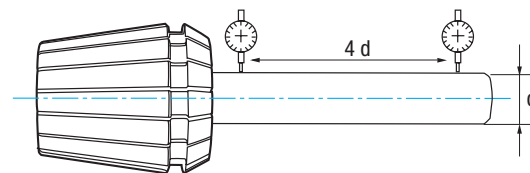

TIPO Type Type	RANGO Range Intervalle	Nº Art.	€
<b>ERC16</b>			
ERC16-3	3	83932	
ERC16-4	4	83933	
ERC16-5	5	83934	
ERC16-6	6	83935	
ERC16-7	7	83936	
ERC16-8	8	83937	
ERC16-9	9	83938	
ERC16-10	10	83939	

TIPO Type Type	RANGO Range Intervalle	Nº Art.	€
<b>ERC25</b>			
ERC25-3	3	83951	
ERC25-4	4	83952	
ERC25-5	5	83953	
ERC25-6	6	83954	
ERC25-7	7	83955	
ERC25-8	8	83956	
ERC25-9	9	83957	
ERC25-10	10	83958	
ERC25-11	11	83959	
ERC25-12	12	83960	
ERC25-13	13	83961	
ERC25-14	14	83962	
ERC25-15	15	83963	
ERC25-16	16	83964	

TIPO Type Type	RANGO Range Intervalle	Nº Art.	€
<b>ERC40</b>			
ERC40-3	3	83982	
ERC40-4	4	83983	
ERC40-5	5	83984	
ERC40-6	6	83985	
ERC40-7	7	83986	
ERC40-8	8	83987	
ERC40-9	9	83988	
ERC40-10	10	83989	
ERC40-11	11	83990	
ERC40-12	12	83991	
ERC40-13	13	83992	
ERC40-14	14	83993	
ERC40-15	15	83994	
ERC40-16	16	83995	
ERC40-17	17	83996	
ERC40-18	18	83997	
ERC40-19	19	83998	
ERC40-20	20	83999	
ERC40-21	21	84000	
ERC40-22	22	84001	
ERC40-23	23	84002	
ERC40-24	24	84003	
ERC40-25	25	84004	
ERC40-26	26	84005	

TIPO Type Type	RANGO Range Intervalle	Nº Art.	€
<b>ERC20</b>			
ERC20-3	3	83940	
ERC20-4	4	83941	
ERC20-5	5	83942	
ERC20-6	6	83943	
ERC20-7	7	83944	
ERC20-8	8	83945	
ERC20-9	9	83946	
ERC20-10	10	83947	
ERC20-11	11	83948	
ERC20-12	12	83949	
ERC20-13	13	83950	

TIPO Type Type	RANGO Range Intervalle	Nº Art.	€
<b>ERC32</b>			
ERC32-3	3	83965	
ERC32-4	4	83966	
ERC32-5	5	83967	
ERC32-6	6	83925	
ERC32-7	7	83968	
ERC32-8	8	83969	
ERC32-9	9	83970	
ERC32-10	10	83971	
ERC32-11	11	83972	
ERC32-12	12	83973	
ERC32-13	13	83974	
ERC32-14	14	83975	
ERC32-15	15	83976	
ERC32-16	16	83977	
ERC32-17	17	83978	
ERC32-18	18	83979	
ERC32-19	19	83980	
ERC32-20	20	83981	



Set	Pcs	Cont.	Nº Art.	Set Price!
ERC16	8	3 - 4 - 5 - 6 - 7 - 8 - 9 - 10	84006	
ERC20	11	3 - 4 - 5 - 6 - 7 - 8 - 9 - 10 - 11 - 12 - 13	84007	
ERC25	14	3 - 4 - 5 - 6 - 7 - 8 - 9 - 10 - 11 - 12 - 13 - 14 - 15 - 16	84008	

Set	Pcs	Cont.	Nº Art.	Set Price!
ERC32	18	3 - 4 - 5 - 6 - 7 - 8 - 9 - 10 - 11 - 12 - 13 - 14 - 15 - 16 - 17 - 18 - 19 - 20	84009	
ERC40	24	3 - 4 - 5 - 6 - 7 - 8 - 9 - 10 - 11 - 12 - 13 - 14 - 15 - 16 - 17 - 18 - 19 - 20 - 21 - 22 - 23 - 24 - 25 - 26	84010	





Ref. **8395**

**PINZAS DE SUJECIÓN DE GRAN APRIETE DE ALTA PRECISIÓN**

High Precision Strong Collets

Pinces de fixation de grand serrage haute précision



Clase  
Class Classe  
**A**

Tol.  
**0,01**  
mm

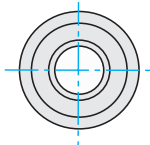
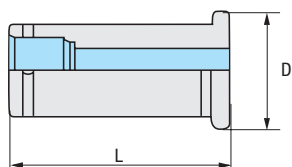
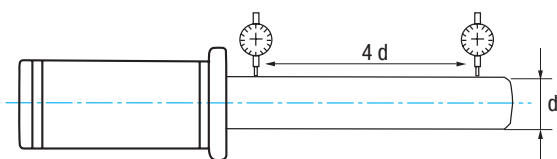

TIPO Type Type	MEDIDA Size Measure	D	L
<b>C20</b>	<b>6, 8, 10, 12, 16</b>	26,00	55,00
<b>C25</b>	<b>6, 8, 10, 12, 16, 20</b>	30,00	63,00
<b>C32</b>	<b>4, 5, 6, 8, 10, 12, 14, 16, 18, 20, 25</b>	38,00	70,00
<b>C42</b>	<b>6, 8, 10, 12, 16, 20, 25, 32</b>	48,00	75,00

TIPO Type Type	Nº Art.	€	TIPO Type Type	Nº Art.	€	TIPO Type Type	Nº Art.	€	TIPO Type Type	Nº Art.	€
<b>C20</b>			<b>C25</b>			<b>C32</b>			<b>C42</b>		
<b>C20-6</b>	25195		<b>C25-6</b>	25212		<b>C32-4</b>	25225		<b>C42-6</b>	25246	
<b>C20-8</b>	25202		<b>C25-8</b>	25213		<b>C32-5</b>	25232		<b>C42-8</b>	25247	
<b>C20-10</b>	25205		<b>C25-10</b>	25214		<b>C32-6</b>	25236		<b>C42-10</b>	25248	
<b>C20-12</b>	25209		<b>C25-12</b>	25215		<b>C32-8</b>	25238		<b>C42-12</b>	25249	
<b>C20-16</b>	25210		<b>C25-16</b>	25216		<b>C32-10</b>	25239		<b>C42-16</b>	25250	
			<b>C25-20</b>	25223		<b>C32-12</b>	25240		<b>C42-20</b>	25251	
						<b>C32-14</b>	25241		<b>C42-25</b>	25252	
						<b>C32-16</b>	25242		<b>C42-32</b>	25254	
						<b>C32-18</b>	25243				
						<b>C32-20</b>	25244				
						<b>C32-25</b>	25245				



Set	Pcs	Cont.	Nº Art.	Set Price!
<b>C20</b>	<b>5</b>	<b>6 - 8 - 10 - 12 - 16</b>	25302	
<b>C32</b>	<b>11</b>	<b>4 - 5 - 6 - 8 - 10 - 12 - 14 - 16 - 18 - 20 - 25</b>	25300	



Ref. 8391



Ref. 8395

AMPLIACION DE GAMA - Range Expansion - Extension de la gamme

Ref. **3415**

**ACEITES DE CORTE Y REFRIGERANTES**  
Cutting Oils & Water Soluble Fluids  
Huiles de coupe et lubrifiants



**MULTI**

**Multiusos**

Multiusos - Multi-purpose - Multifonction



Cont. 400ml  
N° Art. 84040  
€



**Pulveriza abiertamente con la cánula hacia abajo**

Spray openly with the nozzle facing down

Vaporise ouvertement avec la canule vers le bas



**Pulveriza con precisión con la cánula hacia arriba**

Spray precisely with the nozzle facing up

Vaporise précisément avec la canule vers le haut

**APLICACIÓN:**

Mecanizado de aceros duros, inoxidables, aleaciones de cobre y toda clase de metales

Fuertemente aditivado para lubricar y proteger contra la corrosión

**APPLICATION:**

Machining of hard steels, stainless steels, copper alloys and all kinds of metals

Highly additivated for lubrication and corrosion protection

**APPLICATION:**

Usinage d'aciers durs, inoxydables, alliages de cuivre et tous types de métaux

Fortement additivé pour la lubrification et la protection contre la corrosion



**12 UNI**

N° Art.	€
84335	<b>Box Price!</b>

AMPLIACION DE GAMA - Range Expansion - Extension de la gamme

Ref. **9200**

**JUEGOS FRESAS ROTATIVAS MD**  
HM Rotary Burr Sets  
Jeux fraises limes rotatives carbure



**Mod. 5**  
**5 Pcs**



**INOXIDABLES**  
Stainless Steels  
Aciers Inox

Cont. (1 x ref.)	D mm	d mm	Dentado Teeth / Denture M	
			N° Art. MD/HM	€
9251	12,70	6,00	84379	
9254				
9257				
9258	9,60	6,00	84380	
9268				





**NUEVA PUNTA**  
Máximo rendimiento

**NEW TIP**  
Maximum performance



**NOUVELLE POINTE**  
Rendement maximal



Ref. **1015**  
**ZIRKONIO**

**BROCA MANGO CILÍNDRICO ZIRKONIO**  
Zirkonio Straight Shank Drill Bit  
Foret queue cylindrique Zirkonio



▶ Video



**Ángulo punta 118°**

- Autocentradora
- Ideal taladro portátil
- Geometría especial diseñada para reducir el esfuerzo de corte

**Nuevo recubrimiento Zirkonio de última generación por PVD**

- Basado en ZRN
- Bajo coeficiente de fricción
- Muy resistente a la corrosión
- Adecuado para materiales no férricos
- Evita la adherencia de material en el filo de corte

**118° Point Angle**

- Autocentering
- Ideal Portable Drilling Machine
- Special Geometry designed for reducing cutting effort

**Latest generation Zirkonio coating by PVD**

- Based on ZRN
- Low Friction Coefficient
- High Corrosion Resistant
- Appropriate for Non-Ferrous Materials
- Built-Up Edge avoided

**Angle Pointe 118°**

- Autocentreur
- Perceuse à main
- Géométrie pour réduire l'effort de coupe

**Nouveau revêtement Zirkonio dernière génération par PVD**

- Base ZRN
- Faible coefficient friction
- Résistant à l'usure
- Recommandé pour aciers non ferreux
- Évite l'adhérence sur les filets de coupe

Ref. **1052**

**Extra-Corta / Stub / Extra-courte**



Ref. **8400**

**BROCA METAL DURO GRAN RENDIMIENTO CNC 3XD**  
3XD CNC High Performance Carbide Drill Bit  
Foret carbure haut rendement CNC 3XD



Ref. **8405**

**BROCA METAL DURO GRAN RENDIMIENTO CNC 5XD**  
5XD CNC High Performance Carbide Drill Bit  
Foret carbure haut rendement CNC 5XD



Ref. **8410**

**BROCA METAL DURO REFRIGERACIÓN INTERIOR 3XD**  
3XD Internal Cooling Carbide Drill Bit  
Foret carbure lubrification interne 3XD



Ref. **8415**

**BROCA METAL DURO REFRIGERACIÓN INTERIOR 5XD**  
5XD Internal Cooling Carbide Drill Bit  
Foret carbure lubrification interne 5XD



Ref. **9010**

**BROCA METAL DURO SERIE CORTA**  
Carbide Drill Bit. Jobber Series  
Foret carbure série courte



Ref. **1050**

**BROCA MANGO CILÍNDRICO HSS. SERIE EXTRA CORTA**  
HSS Straight Shank Drill Bit. Stub Series  
Foret queue cylindrique HSS. Série extra-courte



Ref. **9060**

**ESCARIADOR MÁQUINA MANGO CILÍNDRICO METAL DURO**  
Solid Carbide Straight Shank Machine Reamer  
Alésoir à machine queue cylindrique carbure





Ref. **3143**

**MACHO RECTO MÁQUINA MÉTRICA MATERIALES ALEADOS M. REFORZADO**  
Reinforced Shank Alloy Materials Metric Machine Straight Tap  
Taraud droit machine métrique matériaux alliages queue renforcée



Ref. **3243**

**MACHO RECTO MÁQUINA MÉTRICA MATERIALES ALEADOS**  
Alloy Materials Metric Machine Straight Tap  
Taraud droit machine métrique matériaux alliages



Ref. **3153**

**MACHO HELICOIDAL MÁQUINA MÉTRICA MATERIALES ALEADOS M. REFORZADO**  
Reinforced Shank Alloy Materials Metric Machine Spiral Tap  
Taraud hélicoïdal machine métrique matériaux alliages queue renforcée



Ref. **3253**

**MACHO HELICOIDAL MÁQUINA MÉTRICA MATERIALES ALEADOS**  
Alloy Materials Metric Machine Spiral Tap  
Taraud hélicoïdal machine métrique matériaux alliages



Ref. **3166**

**MACHO RECTO LARGO MÁQUINA MÉTRICA**  
Metric Machine **Long** Straight Tap  
Taraud droit **long** machine métrique



Ref. **3167**

**MACHO HELICOIDAL LARGO MÁQUINA MÉTRICA**  
Metric Machine **Long** Spiral Tap  
Taraud hélicoïdal **long** machine métrique



Ref. **3119**

**MACHO RECTO MÁQUINA MÉTRICA NORMA ISO 529**  
**ISO 529** Norm Standard Metric Machine Straight Tap  
Taraud droit machine métrique norme **ISO 529**





Ref. **3109**

**MACHO RECTO MÁQUINA MÉTRICA NORMA ISO 529**  
ISO 529 Norm Standard Metric Machine Straight Tap  
Taraud droit machine métrique norme ISO 529



Ref. **3157**

**MACHO HELICOIDAL MÁQUINA MÉTRICA NORMA ISO 529**  
ISO 529 Norm Standard Metric Machine Spiral Tap  
Taraud helicoidal machine métrique norme ISO 529



Ref. **3026**

**JUEGO MACHOS MANO BSP (GAS)**  
BSP (Gas) Hand Tap Set  
Jeu tarauds à main BSP (Gaz)



Ref. **3016**

**MACHO ÚNICO MANO BSP (GAS)**  
BSP (Gas) Hand Tap  
Taraud à main BSP (Gaz)



Ref. **9644**

**FRESA METAL DURO DESBASTE USO GENERAL**  
General Purpose Roughing Carbide End Mill  
Fraise carbure ébauche utilisation générale



Ref. **9647**

**FRESA METAL DURO 3Z DESBASTE 45° INOX**  
Stainless 45° Roughing 3Z Carbide End Mill  
Fraise carbure 3Z ébauche 45° Inox



Ref. **9406**

**FRESA METAL DURO HÉLICE ALTERNA ALTO RENDIMIENTO 48-70 HRC**  
48-70 HRC High Performance Unequal Helix Carbide End Mill  
Fraise carbure hélice alternée haut rendement 48-70 HRC



Ref. **9401**

**FRESA METAL DURO 4Z USO GENERAL**  
General Purpose 4Z Carbide End Mill  
Fraise carbure 4Z utilisation générale



Ref. **9410**

**FRESA METAL DURO 4Z SERIE LARGA USO GENERAL**

General Purpose 4Z Long Series Carbide End Mill  
Fraise carbure 4Z Série longue utilisation générale



Ref. **9412**

**FRESA METAL DURO 4Z CABEZA ESFÉRICA < 55 HRC**

< 55 HRC Ball Nose 4Z Carbide End Mill  
Fraise carbure 4Z hémisphérique. < 55 HRC



Ref. **9407**

**FRESA METAL DURO 4Z SERIE LARGA CABEZA ESFÉRICA < 55 HRC**

< 55 HRC Ball Nose 4Z Long Series Carbide End Mill  
Fraise carbure 4Z série longue hémisphérique < 55 HRC



Ref. **9431**

**FRESA METAL DURO SERIE CORTA 3Z USO GENERAL**

General Purpose 3Z Short Series Carbide End Mill  
Fraise carbure série courte 3Z utilisation générale



Ref. **9421**

**FRESA METAL DURO 2Z USO GENERAL**

General Purpose 2Z Carbide End Mill  
Fraise carbure 2Z utilisation générale



Ref. **9424**

**FRESA METAL DURO SERIE LARGA 2Z USO GENERAL**

General Purpose 2Z Long Series Carbide End Mill  
Fraise carbure série longue 2Z utilisation générale



Ref. **8512**

**PLAQUITA INTERCAMBIABLE TORNEADO CNMM**

CNMM Turning Indexable Insert  
Plaquette tournage CNMM



Ref. **8865**

**PORTA-PLAQUITAS TRONZADO Y RANURADO XMCG**

XMCG Parting & Grooving Tool-Holder Blade  
Porte plaquettes tronçonnage et rainurage XMCG





**IZAR CUTTING TOOLS, S.A.L.**

C.I.F.: A-48932826

Parque Empresarial Boroa 2B2

48340 AMOREBIETA (Bizkaia)

Spain

izartool.com

**COMERCIAL NACIONAL** ✉ [comercial@izartool.com](mailto:comercial@izartool.com)

**PEDIDOS Y  
ATENCIÓN A CLIENTES** ☎ 94 630 02 41

**SERVICIO TÉCNICO** ☎ 94 630 02 43

**EXPORT SALES** ✉ [export@izartool.com](mailto:export@izartool.com)

**ORDERS & CUSTOMER  
ASSISTANCE** ☎ +34 94 630 02 46

**VENTES FRANCE** ✉ [france@izartool.com](mailto:france@izartool.com)  
☎ +34 94 630 02 45



**izartool.com**



Todas nuestras publicaciones se imprimen en papel ecológico procedente de fuentes responsables con el medioambiente y la sociedad.

All our publications are printed on ecological paper from environmentally and socially responsible sources.

Toutes nos publications sont imprimées sur du papier écologique issu de sources écologiquement et socialement responsables.